

1 Product Description

The MagnTek® MT9523 product series is a fully integrated Hall Effect-based isolated linear current sensor device family designed for AC or DC current sensing in industrial, commercial, and communications systems. Each of the MT9523 consists of a precise, low-offset, linear Hall circuit with a low-resistance current conductor path located near the surface of the die. Applied current flowing through this low-resistance current conductor path generates a magnetic field that the Hall IC converts into a proportional voltage. The current is sensed differentially in order to reject common-mode fields, improving accuracy in magnetically noisy environments. Device accuracy is optimized through the close proximity of the magnetic field to the Hall transducer.

A precise, proportional voltage is provided by the low-offset, chopper-stabilized CMOS Hall IC, which has been accurately calibrated when it is manufactured. The output of the device has a positive slope (>VOQ) when an increasing current flows through the primary current conduction path (from pins 1 and 2, to pins 3 and 4). The internal resistance of this conductive path is 1.0 mΩ typical, providing low-power loss. The terminals of the conductive path are electrically isolated from the signal leads (pins 5 through 8). This allows the MT9523 current sensor IC to be used in high-side current sense applications without use other costly isolation techniques.

The MT9523 family provides SOP-8 package to customers, The package is RoHS compliant.

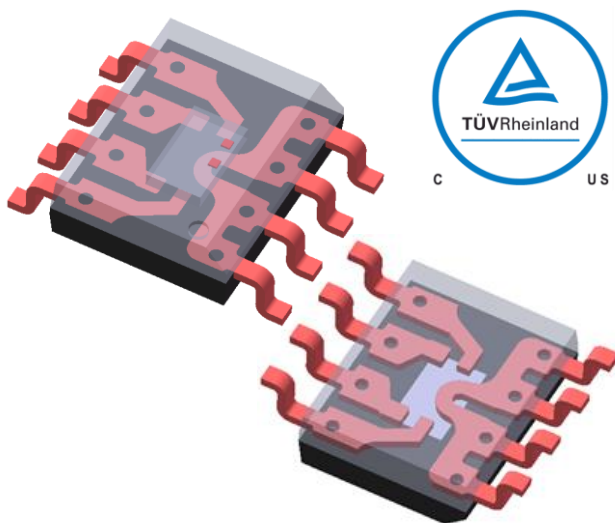

Not to scale

2 Features

- AEC-Q100 Qualified
- ±0.3% Typical Linearity Over Temperature
- Fast Output Response Time: 2.2 μs (typ.)
- 250kHz Signal Bandwidth
- 5.0V/3.3V Power Supply Operation
- Output Mode Option:
 - Ratiometric Output Proportional to Power Supply
 - Fixed Output Out of Proportion to Power Supply
- -40°C~150°C Operating Temperature
- Primary Conductor Resistance
 - 1.0mΩ
- Sensing Current Range: (AC or DC)
 - ±5A, ±10A, ±15A, ±20A, ±25A, ±30A, ±40A, ±50A
 - +10A, +20A, +30A
- Output Voltage Proportional to AC or DC Current
- Extremely Stable Quiescent Output Voltage
- Non-Ratiometric Operation with Reference Output
- Near Zero Magnetic Hysteresis
- Safety Parameters: (UL62368: US72227128 01)
 - 2.5kVrms 1min Dielectric Surge Isolation
 - 450Vrms, 636VDC or VPK Working Voltage
 - 4.2mm Clearance Distance
 - 4.2mm Creepage Distance
- Package Option:
 - SOP-8
- RoHS Compliant: (EU)2015/863

3 Applications

- Medium and low power inverter current sensing
- Motor phase and rail current sensing
- Micro PV inverter
- Chargers and Converters
- EPS
- PTC heater
- DC-DC
- Overcurrent Protection

4 Product Overview of MT9523

料号	描述
MT9523CT	SOP-8 Tape & Reel (3000 pcs/bag)

Table of Contents

1	Product Description.....	1
2	Features.....	1
3	Applications.....	1
4	Product Overview of MT9523.....	1
5	Functional Block Diagram	3
6	Pin Configuration and Function.....	3
7	Naming Specification.....	4
8	Selection Guide.....	4
9	Typical Application Circuit.....	6
10	Electrical and Magnetic Characteristics.....	7
	10.1 Absolute Maximum Ratings.....	7
	10.2 Isolation and Package Characteristics.....	7
	10.3 Life Time Characteristics.....	7
	10.4 ESD Rating.....	8
	10.5 Electrical Characteristics.....	8
	10.6 Accuracy Specifications.....	10
11	Characteristic Definitions.....	30
12	Package Material Information.....	34
	12.1 SOP-8 Package Information.....	34
13	Copy Rights and Disclaimer.....	35

Reversion History

1	Originally Version	
2	Version 1.0	Add AEC-Q100 logo and TUV certification
3	Version 1.1	Update the definition of TPO; add POR parameters
4	Version 1.2	Update Clearance Distance

5 Functional Block Diagram

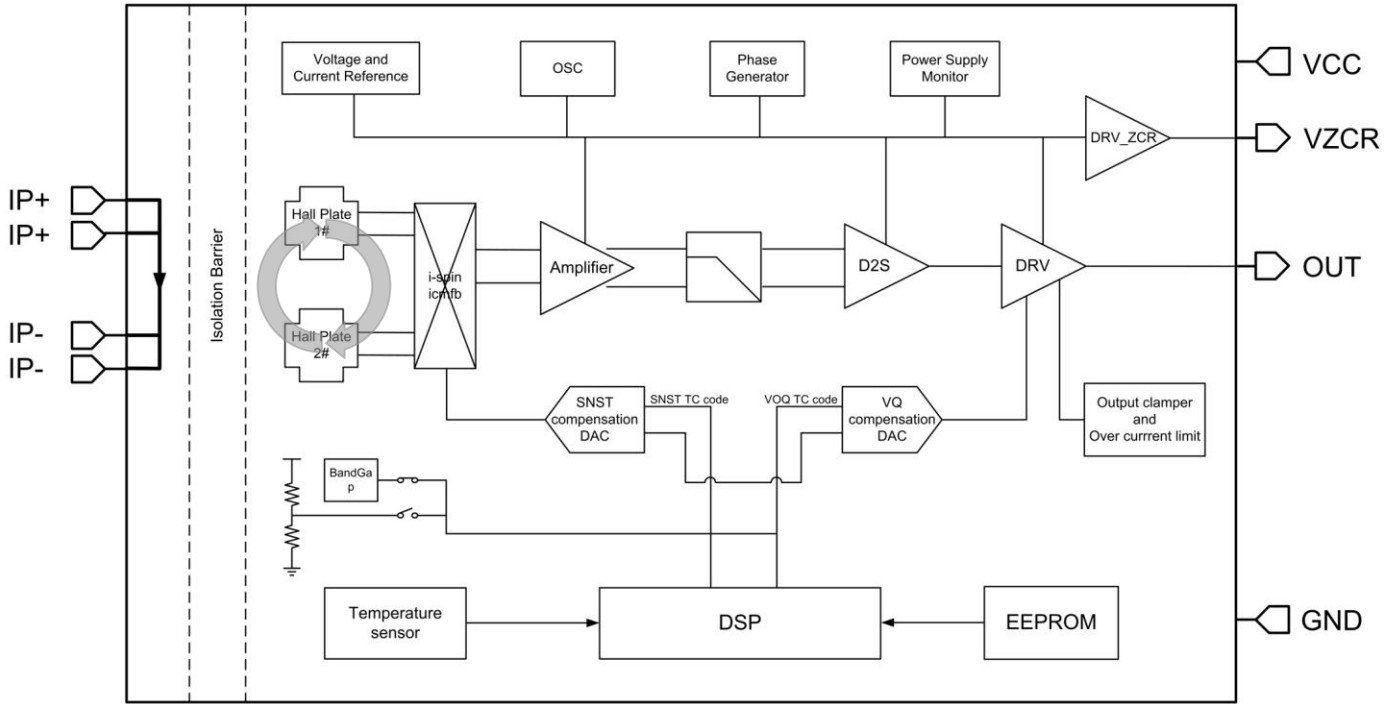

Figure.1 Functional Block Diagram

6 Pin Configuration and Functions

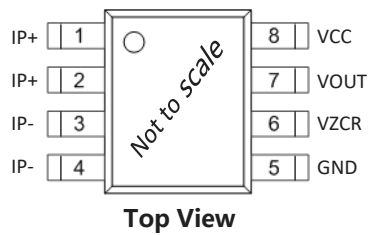
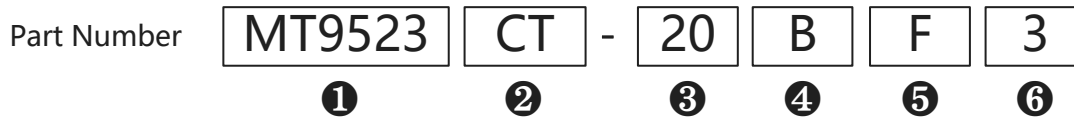

Figure.2 Pin Configuration & Functions (SOP-8)

No.	名称	描述
1, 2	IP+	Input Current Positive Pin
3, 4	IP-	Input Current Negative Pin
5	GND	Signal Ground
6	VZCR	Zero Current Reference Output
7	VOUT	Analog Output Signal
8	VCC	Power Supply

7 Naming Specification



① Series Name

② Package Type

Type	Package Type
CT	SOP-8

③ Input Current Range

Type	Input Current Range
5	Full scale sensing range: 5A
10	Full scale sensing range: 10A
15	Full scale sensing range: 15A
20	Full scale sensing range: 20A
25	Full scale sensing range: 25A
30	Full scale sensing range: 30A
40	Full scale sensing range: 40A
50	Full scale sensing range: 50A

④ Current Polarity

Type	Current Polarity
B	Bidirectional
U	Unidirectional

⑤ Output Mode

Type	Output Mode
R	Ratiometric Output
F	Fixed Output

⑥ Power Supply

Type	Power Supply
3	VCC=3.3V
5	VCC=5V

8 Selection Guide

Ordering P/N	Output Mode	VCC (V)	Current Range (A)	Sensitivity (mV/A)	Package	Qty per Reel (pcs)
MT9523CT-10UR5	Ratio	5	+10	400	SOP-8	3000
MT9523CT-20UR5			+20	200		
MT9523CT-30UR5			+30	133.3		
MT9523CT-05BR5			±5	400		
MT9523CT-10BR5			±10	200		
MT9523CT-20BR5			±20	100		
MT9523CT-25BR5			±25	80		
MT9523CT-30BR5			±30	66.7		
MT9523CT-40BR5			±40	50		
MT9523CT-50BR5			±50	40		

Continued on the next page...

Selection Guide (continued)

Ordering P/N	Output Mode	VCC (V)	Current Range (A)	Sensitivity (mV/A)	Package	Qty per Reel (pcs)
MT9523CT-10UR3	Ratio	3.3	+10	264	SOP-8	3000
MT9523CT-20UR3			+20	132		
MT9523CT-30UR3			+30	88		
MT9523CT-05BR3			±5	264		
MT9523CT-10BR3			±10	132		
MT9523CT-15BR3			±15	88		
MT9523CT-20BR3			±20	66		
MT9523CT-25BR3			±25	52.8		
MT9523CT-30BR3			±30	44		
MT9523CT-40BR3			±40	33		
MT9523CT-50BR3			±50	26.4		
MT9523CT-10UF5			Fix	5		
MT9523CT-20UF5	+20	200				
MT9523CT-30UF5	+30	133.3				
MT9523CT-05BF5	±5	400				
MT9523CT-10BF5	±10	200				
MT9523CT-20BF5	±20	100				
MT9523CT-25BF5	±25	80				
MT9523CT-30BF5	±30	66.7				
MT9523CT-40BF5	±40	50				
MT9523CT-50BF5	±50	40				
MT9523CT-05BF3	Fix	3.3	±5	264		
MT9523CT-10BF3			±10	132		
MT9523CT-15BF3			±15	88		
MT9523CT-20BF3			±20	66		
MT9523CT-25BF3			±25	52.8		
MT9523CT-30BF3			±30	44		
MT9523CT-40BF3			±40	33		
MT9523CT-50BF3			±50	26.4		

9 Typical Application Circuit

- (1) $C_{BYPASS}=0.1\mu F$, **C_{BYPASS} between VCC and GND is necessary**; C_L, C_{L_VZCR} recommended $0.47nF$.
- (2) The "Zero Current Reference Output" can use either single ended output or differential output to interface with ADC or OPA.

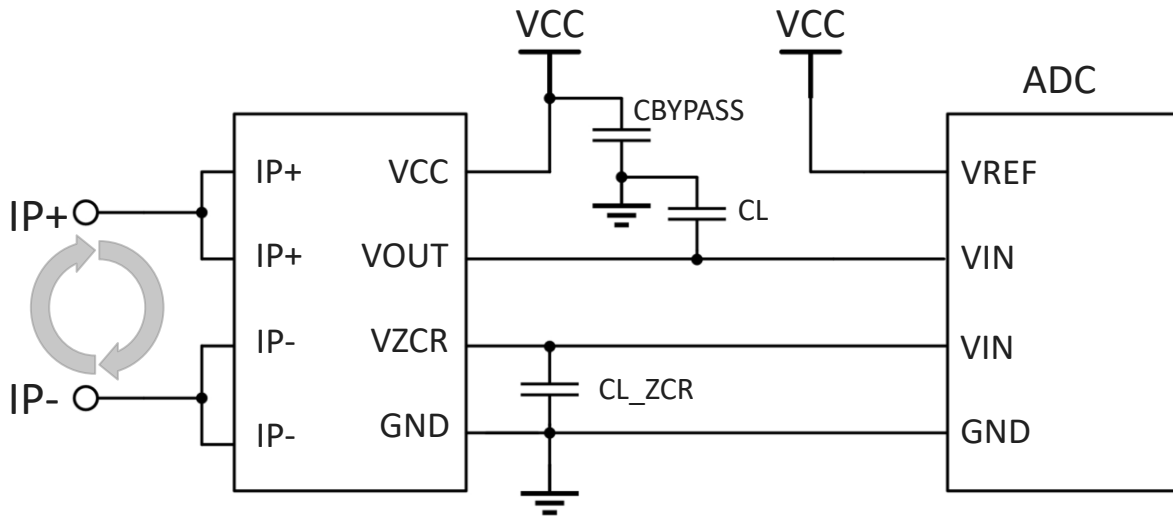

Figure.3 Typical Application Circuit

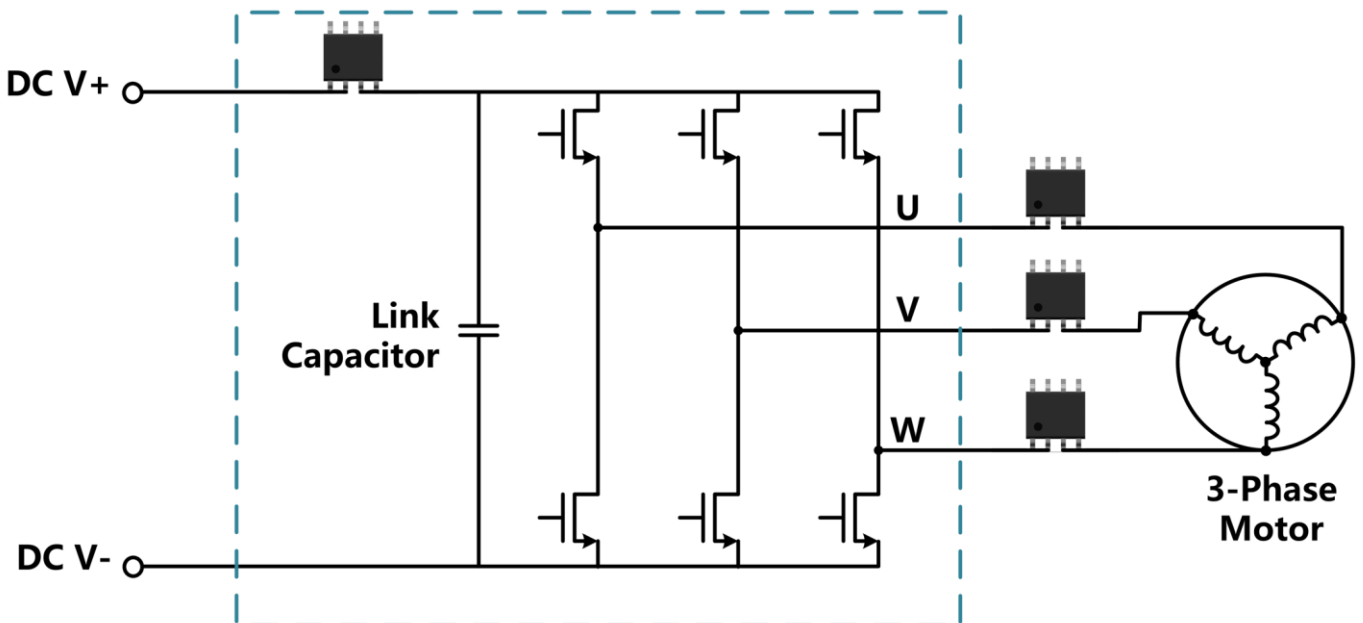

Figure.4 Simplified Three-Phase Inverter Schematic

10 Electrical Magnetic Characteristics

10.1 Absolute Maximum Ratings

Absolute maximum ratings are limited values to be applied individually, and beyond which the serviceability of the circuit may be impaired. Functional operability is not necessarily implied. Exposure to absolute maximum rating conditions for an extended period of time may affect device reliability.

Symbol	Parameters	Min	Max	Units
VCC	Supply Voltage	-	6	V
VRCC	Reverse Battery Voltage	-0.1	-	V
VOUT	Output Voltage	-	VCC+0.5	V
VROUT	Reverse Output Voltage	-0.1	-	V
IOUT(source)	Continuous Output Current	-	40	mA
IOUT(sink)	Continuous Output Current	-	40	mA
TA	Operating Ambient Temperature	-40	150	°C
TS	Storage Temperature	-50	150	°C
TJ	Junction Temperature	-	165	°C

10.2 Isolation and Package Characteristics

Symbol	Parameters	Test Conditions	Value	Units
V _{SURGE}	Dielectric Surge Strength Test Voltage	Tested ±5 pulses at 30 seconds in compliance to IEC 61000-4-5 1.2 / 50 μs (width).	6000	V
V _{ISO}	Dielectric Strength Test Voltage	Test method per UL standard 60950-1 (edition 2). V _{TEST} = V _{ISO} , t = 60 s (qualification); V _{TEST} = 1.2 × V _{ISO} , t = 1 s (100% production)	2500	V _{rms}
V _{IOWM}	Maximum Working Isolation Voltage	Maximum working isolation voltage according to UL60950-1	636	V _{PK} or V _{DC}
			450	V _{rms}
CTI	Comparative Tracking Index	Comparative tracking index according to IEC60112:2009	550	V
D _{CL}	External Clearance	Measured from input terminals to output terminals, shortest distance through air.	4.2	mm
D _{CR}	External Creepage	Measured from input terminals to output terminals, shortest distance path along body.	4.2	mm

10.3 Life Time Characteristics

Symbol	Parameters	Test Condition	Min	Typ	Max	Unit
ESNST_DRIFT	Sensitivity Error Lifetime Drift	TA=-40~125°C	-3	-	3	%
ETOT_DRIFT	Total Output Error Lifetime Drift	TA=-40~125°C	-3	-	3	%

* Based on characterization data obtained during AEC-Q100 stress testing.

10.4 ESD Ratings

Parameters	Reference	Grade
Human-body model (HBM)	AEC-Q100-002	Class IIIA
Charged-device model (CDM)	AEC-Q100-011	Class C3
Latch up	AEC-Q100-004	Class IIA

10.5 Electrical Specifications

TA = -40~150 °C, VCC=3.0~5.5V, CBYPASS=0.1uF (unless otherwise specified)

Symbol	Parameters	Test Condition	Min	Typ	Max	Unit
VCC	Supply Voltage	XXBR5, XXBF5	4.5	5	5.5	V
		XXBR3, XXBF3	3.0	3.3	3.6	V
ICC	Supply Current	VCC=5V, TA=25°C	-	15	22	mA
		VCC=3.3V, TA=25°C	-	13	20	mA
RIP	Primary Conductor Resistance	TA=25°C	-	1.0	-	mΩ
BW	Internal Bandwidth	-3 dB; CL=1 nF	-	250	-	kHz
TPO	Power on time	TA=25°C, CL=1nF, IP=IPR(max) applied	-	1.3	-	ms
VUVLOH	Undervoltage Lockout(UVLO) High Voltage	TA = 25°C, VCC rising and device function enabled	-	4	-	V
VUVLOL	Undervoltage Lockout(UVLO) Low Voltage	TA = 25°C, VCC falling and device function disabled	-	3.75	-	V
VUVLOHYS	UVLO Hysteresis	TA = 25°C	-	0.25	-	V
TUVLOD	UVLO Delay Time	TA = 25°C	-	30	-	us
VPORH	Power-On Reset High Voltage	TA = 25°C, VCC rising	-	2.75	-	V
VPORL	Power-On Reset Low Voltage	TA = 25°C, VCC falling	-	2.55	-	V
VPORHYS	Power-On Reset Hysteresis	TA = 25°C	-	0.2	-	V
TR	Rise time	IP=IPR(max), TA=25°C, CL=1nF	-	1.8	-	us
TPD	Propagation Delay	IP = IPR(max), TA=25°C, CL=1nF	-	1.2	-	us
TRES	Response Time	IP = IPR(max), TA=25°C, CL=1nF	-	2.2	-	us
VOL	Analog Output Low Saturation Level	RL>=4.7KΩ	-	-	0.3	V
VOH	Analog Output High Saturation Level	RL>=4.7KΩ	VCC-0.3	-	-	V
ROUT	DC Output resistance	TA=25°C	-	5	-	Ω
RL	Output RES Load	Pull-down to GND	4.7	-	-	KΩ
		Pull-up to VCC	4.7	-	-	KΩ

* Device may be operated at higher primary current levels, ambient temperatures, and internal leadframe temperatures, provided the Maximum Junction Temperature, is not exceeded.

Continued on the next page...

Electrical Specifications (continued)At $T_A = -40 \sim 150 \text{ }^\circ\text{C}$, $V_{CC} = 3.0 \sim 5.5\text{V}$, $C_{BYPASS} = 0.1\text{ }\mu\text{F}$ (unless otherwise specified)

Symbol	Parameters	Test Condition	Min	Typ	Max	Unit
CL	Output CAP Load	OUT to GND	-	0.47	1	nF
ROUT_ZCR	DC VZCR Output Resistance	$T_A = 25^\circ\text{C}$	-	5	-	Ω
RL_ZCR	VZCR RES Load	Pull-down to GND	4.7	-	-	K Ω
		Pull-up to VCC	4.7	-	-	K Ω
CL_ZCR	VZCR CAP Load	VZCR to GND	-	0.47	1	nF
IND	Noise Density	$V_{CC} = 5\text{V}$, $T_A = 25^\circ\text{C}$, $CL = 1\text{nF}$	-	105	-	$\mu\text{A}/\sqrt{\text{Hz}}$
		$V_{CC} = 3.3\text{V}$, $T_A = 25^\circ\text{C}$, $CL = 1\text{nF}$	-	180	-	$\mu\text{A}/\sqrt{\text{Hz}}$
ELIN	Nonlinearity error	Full Scale	-1.0	0.3	1.0	%F.S.
ERAT_SNST ¹⁾	Ratiometry Sensitivity Error	$T_A = 25^\circ\text{C}$	-	± 1.5	-	%
ERAT_VOQ ¹⁾	Ratiometry Quiescent Voltage Output Error	$T_A = 25^\circ\text{C}$	-	± 1	-	%
ERAT_VZCR ¹⁾	Ratiometry Zero Current Reference Voltage Output Error	$T_A = 25^\circ\text{C}$	-	± 1	-	%
PSRR_VOQ ²⁾	Power Supply Rejection Ratio VOQ	DC~1kHz, 200mV pk-pk ripple on VCC, $I_P = 0\text{A}$	-	-40	-	dB
PSRR_VZCR ²⁾	Power Supply Rejection Ratio VZCR	DC~1kHz, 200mV pk-pk ripple on VCC, $I_P = 0\text{A}$	-	-45	-	dB
PSRR_SNST ²⁾	Power Supply Rejection Ratio SNST	DC~1kHz, 200mV pk-pk ripple on VCC, $I_P = I_{PR}(\text{max})$	-	-35	-	dB
CMFRR	Common Mode Field Rejection Ratio	Uniform external magnetic field	-	40	-	dB
SNST(match)	Hall Plate Sensitivity Matching	$T_A = 25^\circ\text{C}$	-	± 1	-	%

* Device may be operated at higher primary current levels, ambient temperatures, and internal leadframe temperatures, provided the Maximum Junction Temperature, is not exceeded.

1) ERAT parameter is only applicable to the version with the suffix "xxBRx and xxURx mode"

2) PSRR parameter is only applicable to the version with the suffix "xxBFx and xxUFx mode"

10.6 Accuracy Specifications

MT9523CT-05BR5 $T_A = -40 \sim 150\text{ }^\circ\text{C}$, $V_{CC} = 5\text{V}$, Ratiometric mode (unless otherwise specified)

Symbol	Parameters	Test Condition	Min	Typ	Max	Unit
IPR	Input Current Range		-5	-	5	A
SNST	Sensitivity	$-5\text{A} \leq I_P \leq 5\text{A}$	-	400	-	mV/A
VOQ	Zero-Current Output Voltage		-	$V_{CC} \times 0.5$	-	V
VZCR	Zero-Current Reference Output Voltage		-	$V_{CC} \times 0.5$	-	V
VOE_ZCR	Zero-Current Reference Output Voltage Error	$T_A = 25^\circ\text{C}$	-10	-	10	mV
		$T_A = -40^\circ\text{C}$ to 25°C	-20	-	20	mV
		$T_A = 25^\circ\text{C}$ to 150°C	-20	-	20	mV
VOE	Zero-Current Output Error VOQ-VZCR	$I_P = 0\text{ A}$, $T_A = 25^\circ\text{C}$	-5	-	5	mV
		$I_P = 0\text{ A}$, $T_A = -40^\circ\text{C}$ to 25°C	-20	-	20	mV
		$I_P = 0\text{ A}$, $T_A = 25^\circ\text{C}$ to 150°C	-25	-	25	mV
ESNST	Sensitivity Error	$I_P = 5\text{A}$, $T_A = 25^\circ\text{C}$	-	± 1.0	-	%
		$I_P = 5\text{A}$, $T_A = -40^\circ\text{C}$ to 25°C	-	± 2.5	-	%
		$I_P = 5\text{A}$, $T_A = 25^\circ\text{C}$ to 150°C	-	± 2.2	-	%
ETOT	Total Output Error	$I_P = 5\text{A}$, $T_A = 25^\circ\text{C}$	-	± 1.5	-	%
		$I_P = 5\text{A}$, $T_A = -40^\circ\text{C}$ to 25°C	-	± 3.3	-	%
		$I_P = 5\text{A}$, $T_A = 25^\circ\text{C}$ to 150°C	-	± 3.2	-	%

* Device may be operated at higher primary current levels, ambient temperatures, and internal leadframe temperatures, provided the Maximum Junction Temperature, is not exceeded.

MT9523CT-05BF5 At $T_A = -40 \sim 150\text{ }^\circ\text{C}$, $V_{CC} = 5\text{V}$, Fixed mode (unless otherwise specified)

Symbol	Parameters	Test Condition	Min	Typ	Max	Unit
IPR	Input Current Range		-5	-	5	A
SNST	Sensitivity	$-5\text{A} \leq I_P \leq 5\text{A}$	-	400	-	mV/A
VOQ	Zero-Current Output Voltage		-	2.5	-	V
VZCR	Zero-Current Reference Output Voltage		-	2.5	-	V
VOE_ZCR	Zero-Current Reference Output Voltage Error	$T_A = 25^\circ\text{C}$	-10	-	10	mV
		$T_A = -40^\circ\text{C}$ to 25°C	-20	-	20	mV
		$T_A = 25^\circ\text{C}$ to 150°C	-20	-	20	mV
VOE	Zero-Current Output Error VOQ-VZCR	$I_P = 0\text{ A}$, $T_A = 25^\circ\text{C}$	-5	-	5	mV
		$I_P = 0\text{ A}$, $T_A = -40^\circ\text{C}$ to 25°C	-20	-	20	mV
		$I_P = 0\text{ A}$, $T_A = 25^\circ\text{C}$ to 150°C	-25	-	25	mV
ESNST	Sensitivity Error	$I_P = 5\text{A}$, $T_A = 25^\circ\text{C}$	-	± 1.0	-	%
		$I_P = 5\text{A}$, $T_A = -40^\circ\text{C}$ to 25°C	-	± 2.5	-	%
		$I_P = 5\text{A}$, $T_A = 25^\circ\text{C}$ to 150°C	-	± 2.2	-	%
ETOT	Total Output Error	$I_P = 5\text{A}$, $T_A = 25^\circ\text{C}$	-	± 1.5	-	%
		$I_P = 5\text{A}$, $T_A = -40^\circ\text{C}$ to 25°C	-	± 3.3	-	%
		$I_P = 5\text{A}$, $T_A = 25^\circ\text{C}$ to 150°C	-	± 3.2	-	%

* Device may be operated at higher primary current levels, ambient temperatures, and internal leadframe temperatures, provided the Maximum Junction Temperature, is not exceeded.

MT9523CT-10BR5 $T_A = -40 \sim 150\text{ }^\circ\text{C}$, $V_{CC} = 5\text{V}$, Ratiometric mode (unless otherwise specified)

Symbol	Parameters	Test Condition	Min	Typ	Max	Unit
IPR	Input Current Range		-10	-	10	A
SNST	Sensitivity	$-10\text{A} \leq I_P \leq 10\text{A}$	-	200	-	mV/A
VOQ	Zero-Current Output Voltage		-	$V_{CC} \times 0.5$	-	V
VZCR	Zero-Current Reference Output Voltage		-	$V_{CC} \times 0.5$	-	V
VOE_ZCR	Zero-Current Reference Output Voltage Error	$T_A = 25^\circ\text{C}$	-10	-	10	mV
		$T_A = -40^\circ\text{C}$ to 25°C	-20	-	20	mV
		$T_A = 25^\circ\text{C}$ to 150°C	-20	-	20	mV
VOE	Zero-Current Output Error VOQ-VZCR	$I_P = 0\text{ A}$, $T_A = 25^\circ\text{C}$	-5	-	5	mV
		$I_P = 0\text{ A}$, $T_A = -40^\circ\text{C}$ to 25°C	-20	-	20	mV
		$I_P = 0\text{ A}$, $T_A = 25^\circ\text{C}$ to 150°C	-20	-	20	mV
ESNST	Sensitivity Error	$I_P = 10\text{A}$, $T_A = 25^\circ\text{C}$	-	± 1.0	-	%
		$I_P = 10\text{A}$, $T_A = -40^\circ\text{C}$ to 25°C	-	± 2.5	-	%
		$I_P = 10\text{A}$, $T_A = 25^\circ\text{C}$ to 150°C	-	± 2.2	-	%
ETOT	Total Output Error	$I_P = 10\text{A}$, $T_A = 25^\circ\text{C}$	-	± 1.5	-	%
		$I_P = 10\text{A}$, $T_A = -40^\circ\text{C}$ to 25°C	-	± 3.3	-	%
		$I_P = 10\text{A}$, $T_A = 25^\circ\text{C}$ to 150°C	-	± 3.0	-	%

* Device may be operated at higher primary current levels, ambient temperatures, and internal leadframe temperatures, provided the Maximum Junction Temperature, is not exceeded.

MT9523CT-10BF5 At $T_A = -40 \sim 150\text{ }^\circ\text{C}$, $V_{CC} = 5\text{V}$, Fixed mode (unless otherwise specified)

Symbol	Parameters	Test Condition	Min	Typ	Max	Unit
IPR	Input Current Range		-10	-	10	A
SNST	Sensitivity	$-10\text{A} \leq I_P \leq 10\text{A}$	-	200	-	mV/A
VOQ	Zero-Current Output Voltage		-	2.5	-	V
VZCR	Zero-Current Reference Output Voltage		-	2.5	-	V
VOE_ZCR	Zero-Current Reference Output Voltage Error	$T_A = 25^\circ\text{C}$	-10	-	10	mV
		$T_A = -40^\circ\text{C}$ to 25°C	-20	-	20	mV
		$T_A = 25^\circ\text{C}$ to 150°C	-20	-	20	mV
VOE	Zero-Current Output Error VOQ-VZCR	$I_P = 0\text{ A}$, $T_A = 25^\circ\text{C}$	-5	-	5	mV
		$I_P = 0\text{ A}$, $T_A = -40^\circ\text{C}$ to 25°C	-20	-	20	mV
		$I_P = 0\text{ A}$, $T_A = 25^\circ\text{C}$ to 150°C	-20	-	20	mV
ESNST	Sensitivity Error	$I_P = 10\text{A}$, $T_A = 25^\circ\text{C}$	-	± 1.0	-	%
		$I_P = 10\text{A}$, $T_A = -40^\circ\text{C}$ to 25°C	-	± 2.5	-	%
		$I_P = 10\text{A}$, $T_A = 25^\circ\text{C}$ to 150°C	-	± 2.2	-	%
ETOT	Total Output Error	$I_P = 10\text{A}$, $T_A = 25^\circ\text{C}$	-	± 1.5	-	%
		$I_P = 10\text{A}$, $T_A = -40^\circ\text{C}$ to 25°C	-	± 3.3	-	%
		$I_P = 10\text{A}$, $T_A = 25^\circ\text{C}$ to 150°C	-	± 3.0	-	%

* Device may be operated at higher primary current levels, ambient temperatures, and internal leadframe temperatures, provided the Maximum Junction Temperature, is not exceeded.

MT9523CT-20BR5 $T_A = -40 \sim 150\text{ }^\circ\text{C}$, $V_{CC} = 5\text{V}$, Ratiometric mode (unless otherwise specified)

Symbol	Parameters	Test Condition	Min	Typ	Max	Unit
IPR	Input Current Range		-20	-	20	A
SNST	Sensitivity	$-20\text{A} \leq I_P \leq 20\text{A}$	-	100	-	mV/A
VOQ	Zero-Current Output Voltage		-	$V_{CC} \times 0.5$	-	V
VZCR	Zero-Current Reference Output Voltage		-	$V_{CC} \times 0.5$	-	V
VOE_ZCR	Zero-Current Reference Output Voltage Error	$T_A = 25^\circ\text{C}$	-10	-	10	mV
		$T_A = -40^\circ\text{C}$ to 25°C	-20	-	20	mV
		$T_A = 25^\circ\text{C}$ to 150°C	-20	-	20	mV
VOE	Zero-Current Output Error VOQ-VZCR	$I_P = 0\text{ A}$, $T_A = 25^\circ\text{C}$	-5	-	5	mV
		$I_P = 0\text{ A}$, $T_A = -40^\circ\text{C}$ to 25°C	-20	-	20	mV
		$I_P = 0\text{ A}$, $T_A = 25^\circ\text{C}$ to 150°C	-15	-	15	mV
ESNST	Sensitivity Error	$I_P = 20\text{A}$, $T_A = 25^\circ\text{C}$	-	± 1.0	-	%
		$I_P = 20\text{A}$, $T_A = -40^\circ\text{C}$ to 25°C	-	± 2.5	-	%
		$I_P = 20\text{A}$, $T_A = 25^\circ\text{C}$ to 150°C	-	± 2.2	-	%
ETOT	Total Output Error	$I_P = 20\text{A}$, $T_A = 25^\circ\text{C}$	-	± 1.5	-	%
		$I_P = 20\text{A}$, $T_A = -40^\circ\text{C}$ to 25°C	-	± 3.3	-	%
		$I_P = 20\text{A}$, $T_A = 25^\circ\text{C}$ to 150°C	-	± 2.8	-	%

* Device may be operated at higher primary current levels, ambient temperatures, and internal leadframe temperatures, provided the Maximum Junction Temperature, is not exceeded.

MT9523CT-20BF5 At $T_A = -40 \sim 150\text{ }^\circ\text{C}$, $V_{CC} = 5\text{V}$, Fixed mode (unless otherwise specified)

Symbol	Parameters	Test Condition	Min	Typ	Max	Unit
IPR	Input Current Range		-20	-	20	A
SNST	Sensitivity	$-20\text{A} \leq I_P \leq 20\text{A}$	-	100	-	mV/A
VOQ	Zero-Current Output Voltage		-	2.5	-	V
VZCR	Zero-Current Reference Output Voltage		-	2.5	-	V
VOE_ZCR	Zero-Current Reference Output Voltage Error	$T_A = 25^\circ\text{C}$	-10	-	10	mV
		$T_A = -40^\circ\text{C}$ to 25°C	-20	-	20	mV
		$T_A = 25^\circ\text{C}$ to 150°C	-20	-	20	mV
VOE	Zero-Current Output Error VOQ-VZCR	$I_P = 0\text{ A}$, $T_A = 25^\circ\text{C}$	-5	-	5	mV
		$I_P = 0\text{ A}$, $T_A = -40^\circ\text{C}$ to 25°C	-20	-	20	mV
		$I_P = 0\text{ A}$, $T_A = 25^\circ\text{C}$ to 150°C	-15	-	15	mV
ESNST	Sensitivity Error	$I_P = 20\text{A}$, $T_A = 25^\circ\text{C}$	-	± 1.0	-	%
		$I_P = 20\text{A}$, $T_A = -40^\circ\text{C}$ to 25°C	-	± 2.5	-	%
		$I_P = 20\text{A}$, $T_A = 25^\circ\text{C}$ to 150°C	-	± 2.2	-	%
ETOT	Total Output Error	$I_P = 20\text{A}$, $T_A = 25^\circ\text{C}$	-	± 1.5	-	%
		$I_P = 20\text{A}$, $T_A = -40^\circ\text{C}$ to 25°C	-	± 3.3	-	%
		$I_P = 20\text{A}$, $T_A = 25^\circ\text{C}$ to 150°C	-	± 2.8	-	%

* Device may be operated at higher primary current levels, ambient temperatures, and internal leadframe temperatures, provided the Maximum Junction Temperature, is not exceeded.

MT9523CT-25BR5 $T_A = -40 \sim 150\text{ }^\circ\text{C}$, $V_{CC} = 5\text{V}$, Ratiometric mode (unless otherwise specified)

Symbol	Parameters	Test Condition	Min	Typ	Max	Unit
IPR	Input Current Range		-25	-	25	A
SNST	Sensitivity	$-25\text{A} \leq I_P \leq 25\text{A}$	-	80	-	mV/A
VOQ	Zero-Current Output Voltage		-	$V_{CC} \times 0.5$	-	V
VZCR	Zero-Current Reference Output Voltage		-	$V_{CC} \times 0.5$	-	V
VOE_ZCR	Zero-Current Reference Output Voltage Error	$T_A = 25^\circ\text{C}$	-10	-	10	mV
		$T_A = -40^\circ\text{C}$ to 25°C	-20	-	20	mV
		$T_A = 25^\circ\text{C}$ to 150°C	-20	-	20	mV
VOE	Zero-Current Output Error VOQ-VZCR	$I_P = 0\text{ A}$, $T_A = 25^\circ\text{C}$	-5	-	5	mV
		$I_P = 0\text{ A}$, $T_A = -40^\circ\text{C}$ to 25°C	-20	-	20	mV
		$I_P = 0\text{ A}$, $T_A = 25^\circ\text{C}$ to 150°C	-15	-	15	mV
ESNST	Sensitivity Error	$I_P = 25\text{A}$, $T_A = 25^\circ\text{C}$	-	± 1.0	-	%
		$I_P = 25\text{A}$, $T_A = -40^\circ\text{C}$ to 25°C	-	± 2.5	-	%
		$I_P = 25\text{A}$, $T_A = 25^\circ\text{C}$ to 150°C	-	± 2.2	-	%
ETOT	Total Output Error	$I_P = 25\text{A}$, $T_A = 25^\circ\text{C}$	-	± 1.5	-	%
		$I_P = 25\text{A}$, $T_A = -40^\circ\text{C}$ to 25°C	-	± 3.3	-	%
		$I_P = 25\text{A}$, $T_A = 25^\circ\text{C}$ to 150°C	-	± 2.8	-	%

* Device may be operated at higher primary current levels, ambient temperatures, and internal leadframe temperatures, provided the Maximum Junction Temperature, is not exceeded.

MT9523CT-25BF5 At $T_A = -40 \sim 150\text{ }^\circ\text{C}$, $V_{CC} = 5\text{V}$, Fixed mode (unless otherwise specified)

Symbol	Parameters	Test Condition	Min	Typ	Max	Unit
IPR	Input Current Range		-25	-	25	A
SNST	Sensitivity	$-25\text{A} \leq I_P \leq 25\text{A}$	-	80	-	mV/A
VOQ	Zero-Current Output Voltage		-	2.5	-	V
VZCR	Zero-Current Reference Output Voltage		-	2.5	-	V
VOE_ZCR	Zero-Current Reference Output Voltage Error	$T_A = 25^\circ\text{C}$	-10	-	10	mV
		$T_A = -40^\circ\text{C}$ to 25°C	-20	-	20	mV
		$T_A = 25^\circ\text{C}$ to 150°C	-20	-	20	mV
VOE	Zero-Current Output Error VOQ-VZCR	$I_P = 0\text{ A}$, $T_A = 25^\circ\text{C}$	-5	-	5	mV
		$I_P = 0\text{ A}$, $T_A = -40^\circ\text{C}$ to 25°C	-20	-	20	mV
		$I_P = 0\text{ A}$, $T_A = 25^\circ\text{C}$ to 150°C	-15	-	15	mV
ESNST	Sensitivity Error	$I_P = 25\text{A}$, $T_A = 25^\circ\text{C}$	-	± 1.0	-	%
		$I_P = 25\text{A}$, $T_A = -40^\circ\text{C}$ to 25°C	-	± 2.5	-	%
		$I_P = 25\text{A}$, $T_A = 25^\circ\text{C}$ to 150°C	-	± 2.2	-	%
ETOT	Total Output Error	$I_P = 25\text{A}$, $T_A = 25^\circ\text{C}$	-	± 1.5	-	%
		$I_P = 25\text{A}$, $T_A = -40^\circ\text{C}$ to 25°C	-	± 3.3	-	%
		$I_P = 25\text{A}$, $T_A = 25^\circ\text{C}$ to 150°C	-	± 2.8	-	%

* Device may be operated at higher primary current levels, ambient temperatures, and internal leadframe temperatures, provided the Maximum Junction Temperature, is not exceeded.

MT9523CT-30BR5 $T_A = -40 \sim 150 \text{ }^\circ\text{C}$, $V_{CC} = 5\text{V}$, Ratiometric mode (unless otherwise specified)

Symbol	Parameters	Test Condition	Min	Typ	Max	Unit
IPR	Input Current Range		-30	-	30	A
SNST	Sensitivity	$-30\text{A} \leq I_P \leq 30\text{A}$	-	66.7	-	mV/A
VOQ	Zero-Current Output Voltage		-	$V_{CC} \times 0.5$	-	V
VZCR	Zero-Current Reference Output Voltage		-	$V_{CC} \times 0.5$	-	V
VOE_ZCR	Zero-Current Reference Output Voltage Error	$T_A = 25^\circ\text{C}$	-10	-	10	mV
		$T_A = -40^\circ\text{C}$ to 25°C	-20	-	20	mV
		$T_A = 25^\circ\text{C}$ to 150°C	-20	-	20	mV
VOE	Zero-Current Output Error VOQ-VZCR	$I_P = 0 \text{ A}$, $T_A = 25^\circ\text{C}$	-5	-	5	mV
		$I_P = 0 \text{ A}$, $T_A = -40^\circ\text{C}$ to 25°C	-20	-	20	mV
		$I_P = 0 \text{ A}$, $T_A = 25^\circ\text{C}$ to 150°C	-15	-	15	mV
ESNST	Sensitivity Error	$I_P = 30\text{A}$, $T_A = 25^\circ\text{C}$	-	± 1.0	-	%
		$I_P = 30\text{A}$, $T_A = -40^\circ\text{C}$ to 25°C	-	± 2.5	-	%
		$I_P = 30\text{A}$, $T_A = 25^\circ\text{C}$ to 150°C	-	± 2.2	-	%
ETOT	Total Output Error	$I_P = 30\text{A}$, $T_A = 25^\circ\text{C}$	-	± 1.5	-	%
		$I_P = 30\text{A}$, $T_A = -40^\circ\text{C}$ to 25°C	-	± 3.3	-	%
		$I_P = 30\text{A}$, $T_A = 25^\circ\text{C}$ to 150°C	-	± 2.8	-	%

* Device may be operated at higher primary current levels, ambient temperatures, and internal leadframe temperatures, provided the Maximum Junction Temperature, is not exceeded.

MT9523CT-30BF5 At $T_A = -40 \sim 150 \text{ }^\circ\text{C}$, $V_{CC} = 5\text{V}$, Fixed mode (unless otherwise specified)

Symbol	Parameters	Test Condition	Min	Typ	Max	Unit
IPR	Input Current Range		-30	-	30	A
SNST	Sensitivity	$-30\text{A} \leq I_P \leq 30\text{A}$	-	66.7	-	mV/A
VOQ	Zero-Current Output Voltage		-	2.5	-	V
VZCR	Zero-Current Reference Output Voltage		-	2.5	-	V
VOE_ZCR	Zero-Current Reference Output Voltage Error	$T_A = 25^\circ\text{C}$	-10	-	10	mV
		$T_A = -40^\circ\text{C}$ to 25°C	-20	-	20	mV
		$T_A = 25^\circ\text{C}$ to 150°C	-20	-	20	mV
VOE	Zero-Current Output Error VOQ-VZCR	$I_P = 0 \text{ A}$, $T_A = 25^\circ\text{C}$	-5	-	5	mV
		$I_P = 0 \text{ A}$, $T_A = -40^\circ\text{C}$ to 25°C	-20	-	20	mV
		$I_P = 0 \text{ A}$, $T_A = 25^\circ\text{C}$ to 150°C	-15	-	15	mV
ESNST	Sensitivity Error	$I_P = 30\text{A}$, $T_A = 25^\circ\text{C}$	-	± 1.0	-	%
		$I_P = 30\text{A}$, $T_A = -40^\circ\text{C}$ to 25°C	-	± 2.5	-	%
		$I_P = 30\text{A}$, $T_A = 25^\circ\text{C}$ to 150°C	-	± 2.2	-	%
ETOT	Total Output Error	$I_P = 30\text{A}$, $T_A = 25^\circ\text{C}$	-	± 1.5	-	%
		$I_P = 30\text{A}$, $T_A = -40^\circ\text{C}$ to 25°C	-	± 3.3	-	%
		$I_P = 30\text{A}$, $T_A = 25^\circ\text{C}$ to 150°C	-	± 2.8	-	%

* Device may be operated at higher primary current levels, ambient temperatures, and internal leadframe temperatures, provided the Maximum Junction Temperature, is not exceeded.

MT9523CT-40BR5 $T_A = -40 \sim 150\text{ }^\circ\text{C}$, $V_{CC} = 5\text{V}$, Ratiometric mode (unless otherwise specified)

Symbol	Parameters	Test Condition	Min	Typ	Max	Unit
IPR	Input Current Range		-40	-	40	A
SNST	Sensitivity	$-40\text{A} \leq I_P \leq 40\text{A}$	-	50	-	mV/A
VOQ	Zero-Current Output Voltage		-	$V_{CC} \times 0.5$	-	V
VZCR	Zero-Current Reference Output Voltage		-	$V_{CC} \times 0.5$	-	V
VOE_ZCR	Zero-Current Reference Output Voltage Error	$T_A = 25^\circ\text{C}$	-10	-	10	mV
		$T_A = -40^\circ\text{C}$ to 25°C	-20	-	20	mV
		$T_A = 25^\circ\text{C}$ to 150°C	-20	-	20	mV
VOE	Zero-Current Output Error VOQ-VZCR	$I_P = 0\text{ A}$, $T_A = 25^\circ\text{C}$	-5	-	5	mV
		$I_P = 0\text{ A}$, $T_A = -40^\circ\text{C}$ to 25°C	-20	-	20	mV
		$I_P = 0\text{ A}$, $T_A = 25^\circ\text{C}$ to 150°C	-15	-	15	mV
ESNST	Sensitivity Error	$I_P = 40\text{A}$, $T_A = 25^\circ\text{C}$	-	± 1.0	-	%
		$I_P = 40\text{A}$, $T_A = -40^\circ\text{C}$ to 25°C	-	± 2.5	-	%
		$I_P = 40\text{A}$, $T_A = 25^\circ\text{C}$ to 150°C	-	± 2.5	-	%
ETOT	Total Output Error	$I_P = 40\text{A}$, $T_A = 25^\circ\text{C}$	-	± 1.5	-	%
		$I_P = 40\text{A}$, $T_A = -40^\circ\text{C}$ to 25°C	-	± 3.3	-	%
		$I_P = 40\text{A}$, $T_A = 25^\circ\text{C}$ to 150°C	-	± 3.1	-	%

* Device may be operated at higher primary current levels, ambient temperatures, and internal leadframe temperatures, provided the Maximum Junction Temperature, is not exceeded.

MT9523CT-40BF5 At $T_A = -40 \sim 150\text{ }^\circ\text{C}$, $V_{CC} = 5\text{V}$, Fixed mode (unless otherwise specified)

Symbol	Parameters	Test Condition	Min	Typ	Max	Unit
IPR	Input Current Range		-40	-	40	A
SNST	Sensitivity	$-40\text{A} \leq I_P \leq 40\text{A}$	-	50	-	mV/A
VOQ	Zero-Current Output Voltage		-	2.5	-	V
VZCR	Zero-Current Reference Output Voltage		-	2.5	-	V
VOE_ZCR	Zero-Current Reference Output Voltage Error	$T_A = 25^\circ\text{C}$	-10	-	10	mV
		$T_A = -40^\circ\text{C}$ to 25°C	-20	-	20	mV
		$T_A = 25^\circ\text{C}$ to 150°C	-20	-	20	mV
VOE	Zero-Current Output Error VOQ-VZCR	$I_P = 0\text{ A}$, $T_A = 25^\circ\text{C}$	-5	-	5	mV
		$I_P = 0\text{ A}$, $T_A = -40^\circ\text{C}$ to 25°C	-20	-	20	mV
		$I_P = 0\text{ A}$, $T_A = 25^\circ\text{C}$ to 150°C	-15	-	15	mV
ESNST	Sensitivity Error	$I_P = 40\text{A}$, $T_A = 25^\circ\text{C}$	-	± 1.0	-	%
		$I_P = 40\text{A}$, $T_A = -40^\circ\text{C}$ to 25°C	-	± 2.5	-	%
		$I_P = 40\text{A}$, $T_A = 25^\circ\text{C}$ to 150°C	-	± 2.5	-	%
ETOT	Total Output Error	$I_P = 40\text{A}$, $T_A = 25^\circ\text{C}$	-	± 1.5	-	%
		$I_P = 40\text{A}$, $T_A = -40^\circ\text{C}$ to 25°C	-	± 3.3	-	%
		$I_P = 40\text{A}$, $T_A = 25^\circ\text{C}$ to 150°C	-	± 3.1	-	%

* Device may be operated at higher primary current levels, ambient temperatures, and internal leadframe temperatures, provided the Maximum Junction Temperature, is not exceeded.

MT9523CT-50BR5 $T_A = -40 \sim 150\text{ }^\circ\text{C}$, $V_{CC} = 5\text{V}$, Ratiometric mode (unless otherwise specified)

Symbol	Parameters	Test Condition	Min	Typ	Max	Unit
IPR	Input Current Range		-50	-	50	A
SNST	Sensitivity	$-50\text{A} \leq I_P \leq 50\text{A}$	-	40	-	mV/A
VOQ	Zero-Current Output Voltage		-	$V_{CC} \times 0.5$	-	V
VZCR	Zero-Current Reference Output Voltage		-	$V_{CC} \times 0.5$	-	V
VOE_ZCR	Zero-Current Reference Output Voltage Error	$T_A = 25^\circ\text{C}$	-10	-	10	mV
		$T_A = -40^\circ\text{C}$ to 25°C	-20	-	20	mV
		$T_A = 25^\circ\text{C}$ to 150°C	-20	-	20	mV
VOE	Zero-Current Output Error VOQ-VZCR	$I_P = 0\text{ A}$, $T_A = 25^\circ\text{C}$	-5	-	5	mV
		$I_P = 0\text{ A}$, $T_A = -40^\circ\text{C}$ to 25°C	-20	-	20	mV
		$I_P = 0\text{ A}$, $T_A = 25^\circ\text{C}$ to 150°C	-15	-	15	mV
ESNST	Sensitivity Error	$I_P = 50\text{A}$, $T_A = 25^\circ\text{C}$	-	± 1.0	-	%
		$I_P = 50\text{A}$, $T_A = -40^\circ\text{C}$ to 25°C	-	± 2.5	-	%
		$I_P = 50\text{A}$, $T_A = 25^\circ\text{C}$ to 150°C	-	± 2.5	-	%
ETOT	Total Output Error	$I_P = 50\text{A}$, $T_A = 25^\circ\text{C}$	-	± 1.5	-	%
		$I_P = 50\text{A}$, $T_A = -40^\circ\text{C}$ to 25°C	-	± 3.3	-	%
		$I_P = 50\text{A}$, $T_A = 25^\circ\text{C}$ to 150°C	-	± 3.1	-	%

* Device may be operated at higher primary current levels, ambient temperatures, and internal leadframe temperatures, provided the Maximum Junction Temperature, is not exceeded.

MT9523CT-50BF5 At $T_A = -40 \sim 150\text{ }^\circ\text{C}$, $V_{CC} = 5\text{V}$, Fixed mode (unless otherwise specified)

Symbol	Parameters	Test Condition	Min	Typ	Max	Unit
IPR	Input Current Range		-50	-	50	A
SNST	Sensitivity	$-50\text{A} \leq I_P \leq 50\text{A}$	-	40	-	mV/A
VOQ	Zero-Current Output Voltage		-	2.5	-	V
VZCR	Zero-Current Reference Output Voltage		-	2.5	-	V
VOE_ZCR	Zero-Current Reference Output Voltage Error	$T_A = 25^\circ\text{C}$	-10	-	10	mV
		$T_A = -40^\circ\text{C}$ to 25°C	-20	-	20	mV
		$T_A = 25^\circ\text{C}$ to 150°C	-20	-	20	mV
VOE	Zero-Current Output Error VOQ-VZCR	$I_P = 0\text{ A}$, $T_A = 25^\circ\text{C}$	-5	-	5	mV
		$I_P = 0\text{ A}$, $T_A = -40^\circ\text{C}$ to 25°C	-20	-	20	mV
		$I_P = 0\text{ A}$, $T_A = 25^\circ\text{C}$ to 150°C	-15	-	15	mV
ESNST	Sensitivity Error	$I_P = 50\text{A}$, $T_A = 25^\circ\text{C}$	-	± 1.0	-	%
		$I_P = 50\text{A}$, $T_A = -40^\circ\text{C}$ to 25°C	-	± 2.5	-	%
		$I_P = 50\text{A}$, $T_A = 25^\circ\text{C}$ to 150°C	-	± 2.5	-	%
ETOT	Total Output Error	$I_P = 50\text{A}$, $T_A = 25^\circ\text{C}$	-	± 1.5	-	%
		$I_P = 50\text{A}$, $T_A = -40^\circ\text{C}$ to 25°C	-	± 3.3	-	%
		$I_P = 50\text{A}$, $T_A = 25^\circ\text{C}$ to 150°C	-	± 3.1	-	%

* Device may be operated at higher primary current levels, ambient temperatures, and internal leadframe temperatures, provided the Maximum Junction Temperature, is not exceeded.

MT9523CT-10UR5 $T_A = -40 \sim 150\text{ }^\circ\text{C}$, $V_{CC} = 5\text{V}$, Ratiometric mode (unless otherwise specified)

Symbol	Parameters	Test Condition	Min	Typ	Max	Unit
IPR	Input Current Range		0	-	10	A
SNST	Sensitivity	$0A \leq I_P \leq 10A$	-	400	-	mV/A
VOQ	Zero-Current Output Voltage		-	$V_{CC} \times 0.1$	-	V
VZCR	Zero-Current Reference Output Voltage		-	$V_{CC} \times 0.1$	-	V
VOE_ZCR	Zero-Current Reference Output Voltage Error	$T_A = 25^\circ\text{C}$	-10	-	10	mV
		$T_A = -40^\circ\text{C}$ to 25°C	-20	-	20	mV
		$T_A = 25^\circ\text{C}$ to 150°C	-20	-	20	mV
VOE	Zero-Current Output Error VOQ-VZCR	$I_P = 0\text{ A}$, $T_A = 25^\circ\text{C}$	-5	-	5	mV
		$I_P = 0\text{ A}$, $T_A = -40^\circ\text{C}$ to 25°C	-20	-	20	mV
		$I_P = 0\text{ A}$, $T_A = 25^\circ\text{C}$ to 150°C	-25	-	25	mV
ESNST	Sensitivity Error	$I_P = 10\text{A}$, $T_A = 25^\circ\text{C}$	-	± 1.0	-	%
		$I_P = 10\text{A}$, $T_A = -40^\circ\text{C}$ to 25°C	-	± 2.5	-	%
		$I_P = 10\text{A}$, $T_A = 25^\circ\text{C}$ to 150°C	-	± 2.2	-	%
ETOT	Total Output Error	$I_P = 10\text{A}$, $T_A = 25^\circ\text{C}$	-	± 1.5	-	%
		$I_P = 10\text{A}$, $T_A = -40^\circ\text{C}$ to 25°C	-	± 3.3	-	%
		$I_P = 10\text{A}$, $T_A = 25^\circ\text{C}$ to 150°C	-	± 3.2	-	%

* Device may be operated at higher primary current levels, ambient temperatures, and internal leadframe temperatures, provided the Maximum Junction Temperature, is not exceeded.

MT9523CT-10UF5 At $T_A = -40 \sim 150\text{ }^\circ\text{C}$, $V_{CC} = 5\text{V}$, Fixed mode (unless otherwise specified)

Symbol	Parameters	Test Condition	Min	Typ	Max	Unit
IPR	Input Current Range		0	-	10	A
SNST	Sensitivity	$0A \leq I_P \leq 10A$	-	400	-	mV/A
VOQ	Zero-Current Output Voltage		-	0.5	-	V
VZCR	Zero-Current Reference Output Voltage		-	0.5	-	V
VOE_ZCR	Zero-Current Reference Output Voltage Error	$T_A = 25^\circ\text{C}$	-10	-	10	mV
		$T_A = -40^\circ\text{C}$ to 25°C	-20	-	20	mV
		$T_A = 25^\circ\text{C}$ to 150°C	-20	-	20	mV
VOE	Zero-Current Output Error VOQ-VZCR	$I_P = 0\text{ A}$, $T_A = 25^\circ\text{C}$	-5	-	5	mV
		$I_P = 0\text{ A}$, $T_A = -40^\circ\text{C}$ to 25°C	-20	-	20	mV
		$I_P = 0\text{ A}$, $T_A = 25^\circ\text{C}$ to 150°C	-25	-	25	mV
ESNST	Sensitivity Error	$I_P = 10\text{A}$, $T_A = 25^\circ\text{C}$	-	± 1.0	-	%
		$I_P = 10\text{A}$, $T_A = -40^\circ\text{C}$ to 25°C	-	± 2.5	-	%
		$I_P = 10\text{A}$, $T_A = 25^\circ\text{C}$ to 150°C	-	± 2.2	-	%
ETOT	Total Output Error	$I_P = 10\text{A}$, $T_A = 25^\circ\text{C}$	-	± 1.5	-	%
		$I_P = 10\text{A}$, $T_A = -40^\circ\text{C}$ to 25°C	-	± 3.3	-	%
		$I_P = 10\text{A}$, $T_A = 25^\circ\text{C}$ to 150°C	-	± 3.2	-	%

* Device may be operated at higher primary current levels, ambient temperatures, and internal leadframe temperatures, provided the Maximum Junction Temperature, is not exceeded.

MT9523CT-20UR5 $T_A = -40 \sim 150\text{ }^\circ\text{C}$, $V_{CC} = 5\text{V}$, Ratiometric mode (unless otherwise specified)

Symbol	Parameters	Test Condition	Min	Typ	Max	Unit
IPR	Input Current Range		0	-	20	A
SNST	Sensitivity	$0A \leq IP \leq 20A$	-	200	-	mV/A
VOQ	Zero-Current Output Voltage		-	$V_{CC} \times 0.1$	-	V
VZCR	Zero-Current Reference Output Voltage		-	$V_{CC} \times 0.1$	-	V
VOE_ZCR	Zero-Current Reference Output Voltage Error	$T_A = 25^\circ\text{C}$	-10	-	10	mV
		$T_A = -40^\circ\text{C}$ to 25°C	-20	-	20	mV
		$T_A = 25^\circ\text{C}$ to 150°C	-20	-	20	mV
VOE	Zero-Current Output Error VOQ-VZCR	$IP = 0\text{ A}$, $T_A = 25^\circ\text{C}$	-5	-	5	mV
		$IP = 0\text{ A}$, $T_A = -40^\circ\text{C}$ to 25°C	-20	-	20	mV
		$IP = 0\text{ A}$, $T_A = 25^\circ\text{C}$ to 150°C	-15	-	15	mV
ESNST	Sensitivity Error	$IP = 20\text{A}$, $T_A = 25^\circ\text{C}$	-	± 1.0	-	%
		$IP = 20\text{A}$, $T_A = -40^\circ\text{C}$ to 25°C	-	± 2.5	-	%
		$IP = 20\text{A}$, $T_A = 25^\circ\text{C}$ to 150°C	-	± 2.2	-	%
ETOT	Total Output Error	$IP = 20\text{A}$, $T_A = 25^\circ\text{C}$	-	± 1.5	-	%
		$IP = 20\text{A}$, $T_A = -40^\circ\text{C}$ to 25°C	-	± 3.3	-	%
		$IP = 20\text{A}$, $T_A = 25^\circ\text{C}$ to 150°C	-	± 2.8	-	%

* Device may be operated at higher primary current levels, ambient temperatures, and internal leadframe temperatures, provided the Maximum Junction Temperature, is not exceeded.

MT9523CT-20UF5 At $T_A = -40 \sim 150\text{ }^\circ\text{C}$, $V_{CC} = 5\text{V}$, Fixed mode (unless otherwise specified)

Symbol	Parameters	Test Condition	Min	Typ	Max	Unit
IPR	Input Current Range		0	-	20	A
SNST	Sensitivity	$0A \leq IP \leq 20A$	-	200	-	mV/A
VOQ	Zero-Current Output Voltage		-	0.5	-	V
VZCR	Zero-Current Reference Output Voltage		-	0.5	-	V
VOE_ZCR	Zero-Current Reference Output Voltage Error	$T_A = 25^\circ\text{C}$	-10	-	10	mV
		$T_A = -40^\circ\text{C}$ to 25°C	-20	-	20	mV
		$T_A = 25^\circ\text{C}$ to 150°C	-20	-	20	mV
VOE	Zero-Current Output Error VOQ-VZCR	$IP = 0\text{ A}$, $T_A = 25^\circ\text{C}$	-5	-	5	mV
		$IP = 0\text{ A}$, $T_A = -40^\circ\text{C}$ to 25°C	-20	-	20	mV
		$IP = 0\text{ A}$, $T_A = 25^\circ\text{C}$ to 150°C	-15	-	15	mV
ESNST	Sensitivity Error	$IP = 20\text{A}$, $T_A = 25^\circ\text{C}$	-	± 1.0	-	%
		$IP = 20\text{A}$, $T_A = -40^\circ\text{C}$ to 25°C	-	± 2.5	-	%
		$IP = 20\text{A}$, $T_A = 25^\circ\text{C}$ to 150°C	-	± 2.2	-	%
ETOT	Total Output Error	$IP = 20\text{A}$, $T_A = 25^\circ\text{C}$	-	± 1.5	-	%
		$IP = 20\text{A}$, $T_A = -40^\circ\text{C}$ to 25°C	-	± 3.3	-	%
		$IP = 20\text{A}$, $T_A = 25^\circ\text{C}$ to 150°C	-	± 2.8	-	%

* Device may be operated at higher primary current levels, ambient temperatures, and internal leadframe temperatures, provided the Maximum Junction Temperature, is not exceeded.

MT9523CT-30UR5 $T_A = -40 \sim 150\text{ }^\circ\text{C}$, $V_{CC} = 5\text{V}$, Ratiometric mode (unless otherwise specified)

Symbol	Parameters	Test Condition	Min	Typ	Max	Unit
IPR	Input Current Range		0	-	30	A
SNST	Sensitivity	$0A \leq IP \leq 30A$	-	133.3	-	mV/A
VOQ	Zero-Current Output Voltage		-	$V_{CC} \times 0.1$	-	V
VZCR	Zero-Current Reference Output Voltage		-	$V_{CC} \times 0.1$	-	V
VOE_ZCR	Zero-Current Reference Output Voltage Error	$T_A = 25^\circ\text{C}$	-10	-	10	mV
		$T_A = -40^\circ\text{C}$ to 25°C	-20	-	20	mV
		$T_A = 25^\circ\text{C}$ to 150°C	-20	-	20	mV
VOE	Zero-Current Output Error VOQ-VZCR	$IP = 0\text{ A}$, $T_A = 25^\circ\text{C}$	-5	-	5	mV
		$IP = 0\text{ A}$, $T_A = -40^\circ\text{C}$ to 25°C	-20	-	20	mV
		$IP = 0\text{ A}$, $T_A = 25^\circ\text{C}$ to 150°C	-15	-	15	mV
ESNST	Sensitivity Error	$IP = 30\text{A}$, $T_A = 25^\circ\text{C}$	-	± 1.0	-	%
		$IP = 30\text{A}$, $T_A = -40^\circ\text{C}$ to 25°C	-	± 2.5	-	%
		$IP = 30\text{A}$, $T_A = 25^\circ\text{C}$ to 150°C	-	± 2.2	-	%
ETOT	Total Output Error	$IP = 30\text{A}$, $T_A = 25^\circ\text{C}$	-	± 1.5	-	%
		$IP = 30\text{A}$, $T_A = -40^\circ\text{C}$ to 25°C	-	± 3.3	-	%
		$IP = 30\text{A}$, $T_A = 25^\circ\text{C}$ to 150°C	-	± 2.8	-	%

* Device may be operated at higher primary current levels, ambient temperatures, and internal leadframe temperatures, provided the Maximum Junction Temperature, is not exceeded.

MT9523CT-30UF5 At $T_A = -40 \sim 150\text{ }^\circ\text{C}$, $V_{CC} = 5\text{V}$, Fixed mode (unless otherwise specified)

Symbol	Parameters	Test Condition	Min	Typ	Max	Unit
IPR	Input Current Range		0	-	30	A
SNST	Sensitivity	$0A \leq IP \leq 30A$	-	133.3	-	mV/A
VOQ	Zero-Current Output Voltage		-	0.5	-	V
VZCR	Zero-Current Reference Output Voltage		-	0.5	-	V
VOE_ZCR	Zero-Current Reference Output Voltage Error	$T_A = 25^\circ\text{C}$	-10	-	10	mV
		$T_A = -40^\circ\text{C}$ to 25°C	-20	-	20	mV
		$T_A = 25^\circ\text{C}$ to 150°C	-20	-	20	mV
VOE	Zero-Current Output Error VOQ-VZCR	$IP = 0\text{ A}$, $T_A = 25^\circ\text{C}$	-5	-	5	mV
		$IP = 0\text{ A}$, $T_A = -40^\circ\text{C}$ to 25°C	-20	-	20	mV
		$IP = 0\text{ A}$, $T_A = 25^\circ\text{C}$ to 150°C	-15	-	15	mV
ESNST	Sensitivity Error	$IP = 30\text{A}$, $T_A = 25^\circ\text{C}$	-	± 1.0	-	%
		$IP = 30\text{A}$, $T_A = -40^\circ\text{C}$ to 25°C	-	± 2.5	-	%
		$IP = 30\text{A}$, $T_A = 25^\circ\text{C}$ to 150°C	-	± 2.2	-	%
ETOT	Total Output Error	$IP = 30\text{A}$, $T_A = 25^\circ\text{C}$	-	± 1.5	-	%
		$IP = 30\text{A}$, $T_A = -40^\circ\text{C}$ to 25°C	-	± 3.3	-	%
		$IP = 30\text{A}$, $T_A = 25^\circ\text{C}$ to 150°C	-	± 2.8	-	%

* Device may be operated at higher primary current levels, ambient temperatures, and internal leadframe temperatures, provided the Maximum Junction Temperature, is not exceeded.

MT9523CT-05BR3 $T_A = -40 \sim 150\text{ }^\circ\text{C}$, $V_{CC} = 3.3\text{V}$, Ratiometric mode (unless otherwise specified)

Symbol	Parameters	Test Condition	Min	Typ	Max	Unit
IPR	Input Current Range		-5	-	5	A
SNST	Sensitivity	$-5\text{A} \leq I_P \leq 5\text{A}$	-	264	-	mV/A
VOQ	Zero-Current Output Voltage		-	$V_{CC} \times 0.5$	-	V
VZCR	Zero-Current Reference Output Voltage		-	$V_{CC} \times 0.5$	-	V
VOE_ZCR	Zero-Current Reference Output Voltage Error	$T_A = 25^\circ\text{C}$	-10	-	10	mV
		$T_A = -40^\circ\text{C}$ to 25°C	-20	-	20	mV
		$T_A = 25^\circ\text{C}$ to 150°C	-20	-	20	mV
VOE	Zero-Current Output Error VOQ-VZCR	$I_P = 0\text{ A}$, $T_A = 25^\circ\text{C}$	-5	-	5	mV
		$I_P = 0\text{ A}$, $T_A = -40^\circ\text{C}$ to 25°C	-20	-	20	mV
		$I_P = 0\text{ A}$, $T_A = 25^\circ\text{C}$ to 150°C	-25	-	25	mV
ESNST	Sensitivity Error	$I_P = 5\text{A}$, $T_A = 25^\circ\text{C}$	-	± 1.0	-	%
		$I_P = 5\text{A}$, $T_A = -40^\circ\text{C}$ to 25°C	-	± 2.5	-	%
		$I_P = 5\text{A}$, $T_A = 25^\circ\text{C}$ to 150°C	-	± 2.2	-	%
ETOT	Total Output Error	$I_P = 5\text{A}$, $T_A = 25^\circ\text{C}$	-	± 1.5	-	%
		$I_P = 5\text{A}$, $T_A = -40^\circ\text{C}$ to 25°C	-	± 3.3	-	%
		$I_P = 5\text{A}$, $T_A = 25^\circ\text{C}$ to 150°C	-	± 3.2	-	%

* Device may be operated at higher primary current levels, ambient temperatures, and internal leadframe temperatures, provided the Maximum Junction Temperature, is not exceeded.

MT9523CT-05BF3 At $T_A = -40 \sim 150\text{ }^\circ\text{C}$, $V_{CC} = 3.3\text{V}$, Fixed mode (unless otherwise specified)

Symbol	Parameters	Test Condition	Min	Typ	Max	Unit
IPR	Input Current Range		-5	-	5	A
SNST	Sensitivity	$-5\text{A} \leq I_P \leq 5\text{A}$	-	264	-	mV/A
VOQ	Zero-Current Output Voltage		-	1.65	-	V
VZCR	Zero-Current Reference Output Voltage		-	1.65	-	V
VOE_ZCR	Zero-Current Reference Output Voltage Error	$T_A = 25^\circ\text{C}$	-10	-	10	mV
		$T_A = -40^\circ\text{C}$ to 25°C	-20	-	20	mV
		$T_A = 25^\circ\text{C}$ to 150°C	-20	-	20	mV
VOE	Zero-Current Output Error VOQ-VZCR	$I_P = 0\text{ A}$, $T_A = 25^\circ\text{C}$	-5	-	5	mV
		$I_P = 0\text{ A}$, $T_A = -40^\circ\text{C}$ to 25°C	-20	-	20	mV
		$I_P = 0\text{ A}$, $T_A = 25^\circ\text{C}$ to 150°C	-25	-	25	mV
ESNST	Sensitivity Error	$I_P = 5\text{A}$, $T_A = 25^\circ\text{C}$	-	± 1.0	-	%
		$I_P = 5\text{A}$, $T_A = -40^\circ\text{C}$ to 25°C	-	± 2.5	-	%
		$I_P = 5\text{A}$, $T_A = 25^\circ\text{C}$ to 150°C	-	± 2.2	-	%
ETOT	Total Output Error	$I_P = 5\text{A}$, $T_A = 25^\circ\text{C}$	-	± 1.5	-	%
		$I_P = 5\text{A}$, $T_A = -40^\circ\text{C}$ to 25°C	-	± 3.3	-	%
		$I_P = 5\text{A}$, $T_A = 25^\circ\text{C}$ to 150°C	-	± 3.2	-	%

* Device may be operated at higher primary current levels, ambient temperatures, and internal leadframe temperatures, provided the Maximum Junction Temperature, is not exceeded.

MT9523CT-10BR3 $T_A = -40 \sim 150\text{ }^\circ\text{C}$, $V_{CC} = 3.3\text{V}$, Ratiometric mode (unless otherwise specified)

Symbol	Parameters	Test Condition	Min	Typ	Max	Unit
IPR	Input Current Range		-10	-	10	A
SNST	Sensitivity	$-10\text{A} \leq I_P \leq 10\text{A}$	-	132	-	mV/A
VOQ	Zero-Current Output Voltage		-	$V_{CC} \times 0.5$	-	V
VZCR	Zero-Current Reference Output Voltage		-	$V_{CC} \times 0.5$	-	V
VOE_ZCR	Zero-Current Reference Output Voltage Error	$T_A = 25^\circ\text{C}$	-10	-	10	mV
		$T_A = -40^\circ\text{C}$ to 25°C	-20	-	20	mV
		$T_A = 25^\circ\text{C}$ to 150°C	-20	-	20	mV
VOE	Zero-Current Output Error VOQ-VZCR	$I_P = 0\text{ A}$, $T_A = 25^\circ\text{C}$	-5	-	5	mV
		$I_P = 0\text{ A}$, $T_A = -40^\circ\text{C}$ to 25°C	-20	-	20	mV
		$I_P = 0\text{ A}$, $T_A = 25^\circ\text{C}$ to 150°C	-15	-	15	mV
ESNST	Sensitivity Error	$I_P = 10\text{A}$, $T_A = 25^\circ\text{C}$	-	± 1.0	-	%
		$I_P = 10\text{A}$, $T_A = -40^\circ\text{C}$ to 25°C	-	± 2.5	-	%
		$I_P = 10\text{A}$, $T_A = 25^\circ\text{C}$ to 150°C	-	± 2.2	-	%
ETOT	Total Output Error	$I_P = 10\text{A}$, $T_A = 25^\circ\text{C}$	-	± 1.5	-	%
		$I_P = 10\text{A}$, $T_A = -40^\circ\text{C}$ to 25°C	-	± 3.3	-	%
		$I_P = 10\text{A}$, $T_A = 25^\circ\text{C}$ to 150°C	-	± 2.8	-	%

* Device may be operated at higher primary current levels, ambient temperatures, and internal leadframe temperatures, provided the Maximum Junction Temperature, is not exceeded.

MT9523CT-10BF3 At $T_A = -40 \sim 150\text{ }^\circ\text{C}$, $V_{CC} = 3.3\text{V}$, Fixed mode (unless otherwise specified)

Symbol	Parameters	Test Condition	Min	Typ	Max	Unit
IPR	Input Current Range		-10	-	10	A
SNST	Sensitivity	$-10\text{A} \leq I_P \leq 10\text{A}$	-	132	-	mV/A
VOQ	Zero-Current Output Voltage		-	1.65	-	V
VZCR	Zero-Current Reference Output Voltage		-	1.65	-	V
VOE_ZCR	Zero-Current Reference Output Voltage Error	$T_A = 25^\circ\text{C}$	-10	-	10	mV
		$T_A = -40^\circ\text{C}$ to 25°C	-20	-	20	mV
		$T_A = 25^\circ\text{C}$ to 150°C	-20	-	20	mV
VOE	Zero-Current Output Error VOQ-VZCR	$I_P = 0\text{ A}$, $T_A = 25^\circ\text{C}$	-5	-	5	mV
		$I_P = 0\text{ A}$, $T_A = -40^\circ\text{C}$ to 25°C	-20	-	20	mV
		$I_P = 0\text{ A}$, $T_A = 25^\circ\text{C}$ to 150°C	-15	-	15	mV
ESNST	Sensitivity Error	$I_P = 10\text{A}$, $T_A = 25^\circ\text{C}$	-	± 1.0	-	%
		$I_P = 10\text{A}$, $T_A = -40^\circ\text{C}$ to 25°C	-	± 2.5	-	%
		$I_P = 10\text{A}$, $T_A = 25^\circ\text{C}$ to 150°C	-	± 2.2	-	%
ETOT	Total Output Error	$I_P = 10\text{A}$, $T_A = 25^\circ\text{C}$	-	± 1.5	-	%
		$I_P = 10\text{A}$, $T_A = -40^\circ\text{C}$ to 25°C	-	± 3.3	-	%
		$I_P = 10\text{A}$, $T_A = 25^\circ\text{C}$ to 150°C	-	± 2.8	-	%

* Device may be operated at higher primary current levels, ambient temperatures, and internal leadframe temperatures, provided the Maximum Junction Temperature, is not exceeded.

MT9523CT-15BR3 $T_A = -40 \sim 150 \text{ }^\circ\text{C}$, $V_{CC} = 3.3\text{V}$, Ratiometric mode (unless otherwise specified)

Symbol	Parameters	Test Condition	Min	Typ	Max	Unit
IPR	Input Current Range		-15	-	15	A
SNST	Sensitivity	$-15\text{A} \leq I_P \leq 15\text{A}$	-	88	-	mV/A
VOQ	Zero-Current Output Voltage		-	$V_{CC} \times 0.5$	-	V
VZCR	Zero-Current Reference Output Voltage		-	$V_{CC} \times 0.5$	-	V
VOE_ZCR	Zero-Current Reference Output Voltage Error	$T_A = 25^\circ\text{C}$	-10	-	10	mV
		$T_A = -40^\circ\text{C}$ to 25°C	-20	-	20	mV
		$T_A = 25^\circ\text{C}$ to 150°C	-20	-	20	mV
VOE	Zero-Current Output Error VOQ-VZCR	$I_P = 0 \text{ A}$, $T_A = 25^\circ\text{C}$	-5	-	5	mV
		$I_P = 0 \text{ A}$, $T_A = -40^\circ\text{C}$ to 25°C	-20	-	20	mV
		$I_P = 0 \text{ A}$, $T_A = 25^\circ\text{C}$ to 150°C	-15	-	15	mV
ESNST	Sensitivity Error	$I_P = 15\text{A}$, $T_A = 25^\circ\text{C}$	-	± 1.0	-	%
		$I_P = 15\text{A}$, $T_A = -40^\circ\text{C}$ to 25°C	-	± 2.5	-	%
		$I_P = 15\text{A}$, $T_A = 25^\circ\text{C}$ to 150°C	-	± 2.2	-	%
ETOT	Total Output Error	$I_P = 15\text{A}$, $T_A = 25^\circ\text{C}$	-	± 1.5	-	%
		$I_P = 15\text{A}$, $T_A = -40^\circ\text{C}$ to 25°C	-	± 3.3	-	%
		$I_P = 15\text{A}$, $T_A = 25^\circ\text{C}$ to 150°C	-	± 2.8	-	%

* Device may be operated at higher primary current levels, ambient temperatures, and internal leadframe temperatures, provided the Maximum Junction Temperature, is not exceeded.

MT9523CT-15BF3 At $T_A = -40 \sim 150 \text{ }^\circ\text{C}$, $V_{CC} = 3.3\text{V}$, Fixed mode (unless otherwise specified)

Symbol	Parameters	Test Condition	Min	Typ	Max	Unit
IPR	Input Current Range		-15	-	15	A
SNST	Sensitivity	$-15\text{A} \leq I_P \leq 15\text{A}$	-	88	-	mV/A
VOQ	Zero-Current Output Voltage		-	1.65	-	V
VZCR	Zero-Current Reference Output Voltage		-	1.65	-	V
VOE_ZCR	Zero-Current Reference Output Voltage Error	$T_A = 25^\circ\text{C}$	-10	-	10	mV
		$T_A = -40^\circ\text{C}$ to 25°C	-20	-	20	mV
		$T_A = 25^\circ\text{C}$ to 150°C	-20	-	20	mV
VOE	Zero-Current Output Error VOQ-VZCR	$I_P = 0 \text{ A}$, $T_A = 25^\circ\text{C}$	-5	-	5	mV
		$I_P = 0 \text{ A}$, $T_A = -40^\circ\text{C}$ to 25°C	-20	-	20	mV
		$I_P = 0 \text{ A}$, $T_A = 25^\circ\text{C}$ to 150°C	-15	-	15	mV
ESNST	Sensitivity Error	$I_P = 15\text{A}$, $T_A = 25^\circ\text{C}$	-	± 1.0	-	%
		$I_P = 15\text{A}$, $T_A = -40^\circ\text{C}$ to 25°C	-	± 2.5	-	%
		$I_P = 15\text{A}$, $T_A = 25^\circ\text{C}$ to 150°C	-	± 2.2	-	%
ETOT	Total Output Error	$I_P = 15\text{A}$, $T_A = 25^\circ\text{C}$	-	± 1.5	-	%
		$I_P = 15\text{A}$, $T_A = -40^\circ\text{C}$ to 25°C	-	± 3.3	-	%
		$I_P = 15\text{A}$, $T_A = 25^\circ\text{C}$ to 150°C	-	± 2.8	-	%

* Device may be operated at higher primary current levels, ambient temperatures, and internal leadframe temperatures, provided the Maximum Junction Temperature, is not exceeded.

MT9523CT-20BR3 $T_A = -40 \sim 150\text{ }^\circ\text{C}$, $V_{CC} = 3.3\text{V}$, Ratiometric mode (unless otherwise specified)

Symbol	Parameters	Test Condition	Min	Typ	Max	Unit
IPR	Input Current Range		-20	-	20	A
SNST	Sensitivity	$-20\text{A} \leq I_P \leq 20\text{A}$	-	66	-	mV/A
VOQ	Zero-Current Output Voltage		-	$V_{CC} \times 0.5$	-	V
VZCR	Zero-Current Reference Output Voltage		-	$V_{CC} \times 0.5$	-	V
VOE_ZCR	Zero-Current Reference Output Voltage Error	$T_A = 25^\circ\text{C}$	-10	-	10	mV
		$T_A = -40^\circ\text{C}$ to 25°C	-20	-	20	mV
		$T_A = 25^\circ\text{C}$ to 150°C	-20	-	20	mV
VOE	Zero-Current Output Error VOQ-VZCR	$I_P = 0\text{ A}$, $T_A = 25^\circ\text{C}$	-5	-	5	mV
		$I_P = 0\text{ A}$, $T_A = -40^\circ\text{C}$ to 25°C	-20	-	20	mV
		$I_P = 0\text{ A}$, $T_A = 25^\circ\text{C}$ to 150°C	-15	-	15	mV
ESNST	Sensitivity Error	$I_P = 20\text{A}$, $T_A = 25^\circ\text{C}$	-	± 1.0	-	%
		$I_P = 20\text{A}$, $T_A = -40^\circ\text{C}$ to 25°C	-	± 2.5	-	%
		$I_P = 20\text{A}$, $T_A = 25^\circ\text{C}$ to 150°C	-	± 2.2	-	%
ETOT	Total Output Error	$I_P = 20\text{A}$, $T_A = 25^\circ\text{C}$	-	± 1.5	-	%
		$I_P = 20\text{A}$, $T_A = -40^\circ\text{C}$ to 25°C	-	± 3.3	-	%
		$I_P = 20\text{A}$, $T_A = 25^\circ\text{C}$ to 150°C	-	± 2.8	-	%

* Device may be operated at higher primary current levels, ambient temperatures, and internal leadframe temperatures, provided the Maximum Junction Temperature, is not exceeded.

MT9523CT-20BF3 At $T_A = -40 \sim 150\text{ }^\circ\text{C}$, $V_{CC} = 3.3\text{V}$, Fixed mode (unless otherwise specified)

Symbol	Parameters	Test Condition	Min	Typ	Max	Unit
IPR	Input Current Range		-20	-	20	A
SNST	Sensitivity	$-20\text{A} \leq I_P \leq 20\text{A}$	-	66	-	mV/A
VOQ	Zero-Current Output Voltage		-	1.65	-	V
VZCR	Zero-Current Reference Output Voltage		-	1.65	-	V
VOE_ZCR	Zero-Current Reference Output Voltage Error	$T_A = 25^\circ\text{C}$	-10	-	10	mV
		$T_A = -40^\circ\text{C}$ to 25°C	-20	-	20	mV
		$T_A = 25^\circ\text{C}$ to 150°C	-20	-	20	mV
VOE	Zero-Current Output Error VOQ-VZCR	$I_P = 0\text{ A}$, $T_A = 25^\circ\text{C}$	-5	-	5	mV
		$I_P = 0\text{ A}$, $T_A = -40^\circ\text{C}$ to 25°C	-20	-	20	mV
		$I_P = 0\text{ A}$, $T_A = 25^\circ\text{C}$ to 150°C	-15	-	15	mV
ESNST	Sensitivity Error	$I_P = 20\text{A}$, $T_A = 25^\circ\text{C}$	-	± 1.0	-	%
		$I_P = 20\text{A}$, $T_A = -40^\circ\text{C}$ to 25°C	-	± 2.5	-	%
		$I_P = 20\text{A}$, $T_A = 25^\circ\text{C}$ to 150°C	-	± 2.2	-	%
ETOT	Total Output Error	$I_P = 20\text{A}$, $T_A = 25^\circ\text{C}$	-	± 1.5	-	%
		$I_P = 20\text{A}$, $T_A = -40^\circ\text{C}$ to 25°C	-	± 3.3	-	%
		$I_P = 20\text{A}$, $T_A = 25^\circ\text{C}$ to 150°C	-	± 2.8	-	%

* Device may be operated at higher primary current levels, ambient temperatures, and internal leadframe temperatures, provided the Maximum Junction Temperature, is not exceeded.

MT9523CT-25BR3 $T_A = -40 \sim 150 \text{ }^\circ\text{C}$, $V_{CC} = 3.3\text{V}$, Ratiometric mode (unless otherwise specified)

Symbol	Parameters	Test Condition	Min	Typ	Max	Unit
IPR	Input Current Range		-25	-	25	A
SNST	Sensitivity	$-25\text{A} \leq I_P \leq 25\text{A}$	-	52.8	-	mV/A
VOQ	Zero-Current Output Voltage		-	$V_{CC} \times 0.5$	-	V
VZCR	Zero-Current Reference Output Voltage		-	$V_{CC} \times 0.5$	-	V
VOE_ZCR	Zero-Current Reference Output Voltage Error	$T_A = 25^\circ\text{C}$	-10	-	10	mV
		$T_A = -40^\circ\text{C}$ to 25°C	-20	-	20	mV
		$T_A = 25^\circ\text{C}$ to 150°C	-20	-	20	mV
VOE	Zero-Current Output Error VOQ-VZCR	$I_P = 0 \text{ A}$, $T_A = 25^\circ\text{C}$	-5	-	5	mV
		$I_P = 0 \text{ A}$, $T_A = -40^\circ\text{C}$ to 25°C	-20	-	20	mV
		$I_P = 0 \text{ A}$, $T_A = 25^\circ\text{C}$ to 150°C	-15	-	15	mV
ESNST	Sensitivity Error	$I_P = 25\text{A}$, $T_A = 25^\circ\text{C}$	-	± 1.0	-	%
		$I_P = 25\text{A}$, $T_A = -40^\circ\text{C}$ to 25°C	-	± 2.5	-	%
		$I_P = 25\text{A}$, $T_A = 25^\circ\text{C}$ to 150°C	-	± 2.2	-	%
ETOT	Total Output Error	$I_P = 25\text{A}$, $T_A = 25^\circ\text{C}$	-	± 1.5	-	%
		$I_P = 25\text{A}$, $T_A = -40^\circ\text{C}$ to 25°C	-	± 3.3	-	%
		$I_P = 25\text{A}$, $T_A = 25^\circ\text{C}$ to 150°C	-	± 2.8	-	%

* Device may be operated at higher primary current levels, ambient temperatures, and internal leadframe temperatures, provided the Maximum Junction Temperature, is not exceeded.

MT9523CT-25BF3 At $T_A = -40 \sim 150 \text{ }^\circ\text{C}$, $V_{CC} = 3.3\text{V}$, Fixed mode (unless otherwise specified)

Symbol	Parameters	Test Condition	Min	Typ	Max	Unit
IPR	Input Current Range		-25	-	25	A
SNST	Sensitivity	$-25\text{A} \leq I_P \leq 25\text{A}$	-	52.8	-	mV/A
VOQ	Zero-Current Output Voltage		-	1.65	-	V
VZCR	Zero-Current Reference Output Voltage		-	1.65	-	V
VOE_ZCR	Zero-Current Reference Output Voltage Error	$T_A = 25^\circ\text{C}$	-10	-	10	mV
		$T_A = -40^\circ\text{C}$ to 25°C	-20	-	20	mV
		$T_A = 25^\circ\text{C}$ to 150°C	-20	-	20	mV
VOE	Zero-Current Output Error VOQ-VZCR	$I_P = 0 \text{ A}$, $T_A = 25^\circ\text{C}$	-5	-	5	mV
		$I_P = 0 \text{ A}$, $T_A = -40^\circ\text{C}$ to 25°C	-20	-	20	mV
		$I_P = 0 \text{ A}$, $T_A = 25^\circ\text{C}$ to 150°C	-15	-	15	mV
ESNST	Sensitivity Error	$I_P = 25\text{A}$, $T_A = 25^\circ\text{C}$	-	± 1.0	-	%
		$I_P = 25\text{A}$, $T_A = -40^\circ\text{C}$ to 25°C	-	± 2.5	-	%
		$I_P = 25\text{A}$, $T_A = 25^\circ\text{C}$ to 150°C	-	± 2.2	-	%
ETOT	Total Output Error	$I_P = 25\text{A}$, $T_A = 25^\circ\text{C}$	-	± 1.5	-	%
		$I_P = 25\text{A}$, $T_A = -40^\circ\text{C}$ to 25°C	-	± 3.3	-	%
		$I_P = 25\text{A}$, $T_A = 25^\circ\text{C}$ to 150°C	-	± 2.8	-	%

* Device may be operated at higher primary current levels, ambient temperatures, and internal leadframe temperatures, provided the Maximum Junction Temperature, is not exceeded.

MT9523CT-30BR3 $T_A = -40 \sim 150\text{ }^\circ\text{C}$, $V_{CC} = 3.3\text{V}$, Ratiometric mode (unless otherwise specified)

Symbol	Parameters	Test Condition	Min	Typ	Max	Unit
IPR	Input Current Range		-30	-	30	A
SNST	Sensitivity	$-30\text{A} \leq I_P \leq 30\text{A}$	-	44	-	mV/A
VOQ	Zero-Current Output Voltage		-	$V_{CC} \times 0.5$	-	V
VZCR	Zero-Current Reference Output Voltage		-	$V_{CC} \times 0.5$	-	V
VOE_ZCR	Zero-Current Reference Output Voltage Error	$T_A = 25^\circ\text{C}$	-10	-	10	mV
		$T_A = -40^\circ\text{C}$ to 25°C	-20	-	20	mV
		$T_A = 25^\circ\text{C}$ to 150°C	-20	-	20	mV
VOE	Zero-Current Output Error VOQ-VZCR	$I_P = 0\text{ A}$, $T_A = 25^\circ\text{C}$	-5	-	5	mV
		$I_P = 0\text{ A}$, $T_A = -40^\circ\text{C}$ to 25°C	-20	-	20	mV
		$I_P = 0\text{ A}$, $T_A = 25^\circ\text{C}$ to 150°C	-15	-	15	mV
ESNST	Sensitivity Error	$I_P = 30\text{A}$, $T_A = 25^\circ\text{C}$	-	± 1.0	-	%
		$I_P = 30\text{A}$, $T_A = -40^\circ\text{C}$ to 25°C	-	± 2.5	-	%
		$I_P = 30\text{A}$, $T_A = 25^\circ\text{C}$ to 150°C	-	± 2.2	-	%
ETOT	Total Output Error	$I_P = 30\text{A}$, $T_A = 25^\circ\text{C}$	-	± 1.5	-	%
		$I_P = 30\text{A}$, $T_A = -40^\circ\text{C}$ to 25°C	-	± 3.3	-	%
		$I_P = 30\text{A}$, $T_A = 25^\circ\text{C}$ to 150°C	-	± 2.8	-	%

* Device may be operated at higher primary current levels, ambient temperatures, and internal leadframe temperatures, provided the Maximum Junction Temperature, is not exceeded.

MT9523CT-30BF3 At $T_A = -40 \sim 150\text{ }^\circ\text{C}$, $V_{CC} = 3.3\text{V}$, Fixed mode (unless otherwise specified)

Symbol	Parameters	Test Condition	Min	Typ	Max	Unit
IPR	Input Current Range		-30	-	30	A
SNST	Sensitivity	$-30\text{A} \leq I_P \leq 30\text{A}$	-	44	-	mV/A
VOQ	Zero-Current Output Voltage		-	1.65	-	V
VZCR	Zero-Current Reference Output Voltage		-	1.65	-	V
VOE_ZCR	Zero-Current Reference Output Voltage Error	$T_A = 25^\circ\text{C}$	-10	-	10	mV
		$T_A = -40^\circ\text{C}$ to 25°C	-20	-	20	mV
		$T_A = 25^\circ\text{C}$ to 150°C	-20	-	20	mV
VOE	Zero-Current Output Error VOQ-VZCR	$I_P = 0\text{ A}$, $T_A = 25^\circ\text{C}$	-5	-	5	mV
		$I_P = 0\text{ A}$, $T_A = -40^\circ\text{C}$ to 25°C	-20	-	20	mV
		$I_P = 0\text{ A}$, $T_A = 25^\circ\text{C}$ to 150°C	-15	-	15	mV
ESNST	Sensitivity Error	$I_P = 30\text{A}$, $T_A = 25^\circ\text{C}$	-	± 1.0	-	%
		$I_P = 30\text{A}$, $T_A = -40^\circ\text{C}$ to 25°C	-	± 2.5	-	%
		$I_P = 30\text{A}$, $T_A = 25^\circ\text{C}$ to 150°C	-	± 2.2	-	%
ETOT	Total Output Error	$I_P = 30\text{A}$, $T_A = 25^\circ\text{C}$	-	± 1.5	-	%
		$I_P = 30\text{A}$, $T_A = -40^\circ\text{C}$ to 25°C	-	± 3.3	-	%
		$I_P = 30\text{A}$, $T_A = 25^\circ\text{C}$ to 150°C	-	± 2.8	-	%

* Device may be operated at higher primary current levels, ambient temperatures, and internal leadframe temperatures, provided the Maximum Junction Temperature, is not exceeded.

MT9523CT-40BR3 $T_A = -40 \sim 150\text{ }^\circ\text{C}$, $V_{CC} = 3.3\text{V}$, Ratiometric mode (unless otherwise specified)

Symbol	Parameters	Test Condition	Min	Typ	Max	Unit
IPR	Input Current Range		-40	-	40	A
SNST	Sensitivity	$-40\text{A} \leq I_P \leq 40\text{A}$	-	33	-	mV/A
VOQ	Zero-Current Output Voltage		-	$V_{CC} \times 0.5$	-	V
VZCR	Zero-Current Reference Output Voltage		-	$V_{CC} \times 0.5$	-	V
VOE_ZCR	Zero-Current Reference Output Voltage Error	$T_A = 25^\circ\text{C}$	-10	-	10	mV
		$T_A = -40^\circ\text{C}$ to 25°C	-20	-	20	mV
		$T_A = 25^\circ\text{C}$ to 150°C	-20	-	20	mV
VOE	Zero-Current Output Error VOQ-VZCR	$I_P = 0\text{ A}$, $T_A = 25^\circ\text{C}$	-5	-	5	mV
		$I_P = 0\text{ A}$, $T_A = -40^\circ\text{C}$ to 25°C	-20	-	20	mV
		$I_P = 0\text{ A}$, $T_A = 25^\circ\text{C}$ to 150°C	-15	-	15	mV
ESNST	Sensitivity Error	$I_P = 40\text{A}$, $T_A = 25^\circ\text{C}$	-	± 1.0	-	%
		$I_P = 40\text{A}$, $T_A = -40^\circ\text{C}$ to 25°C	-	± 2.5	-	%
		$I_P = 40\text{A}$, $T_A = 25^\circ\text{C}$ to 150°C	-	± 2.5	-	%
ETOT	Total Output Error	$I_P = 40\text{A}$, $T_A = 25^\circ\text{C}$	-	± 1.5	-	%
		$I_P = 40\text{A}$, $T_A = -40^\circ\text{C}$ to 25°C	-	± 3.3	-	%
		$I_P = 40\text{A}$, $T_A = 25^\circ\text{C}$ to 150°C	-	± 3.1	-	%

* Device may be operated at higher primary current levels, ambient temperatures, and internal leadframe temperatures, provided the Maximum Junction Temperature, is not exceeded.

MT9523CT-40BF3 At $T_A = -40 \sim 150\text{ }^\circ\text{C}$, $V_{CC} = 3.3\text{V}$, Fixed mode (unless otherwise specified)

Symbol	Parameters	Test Condition	Min	Typ	Max	Unit
IPR	Input Current Range		-40	-	40	A
SNST	Sensitivity	$-40\text{A} \leq I_P \leq 40\text{A}$	-	33	-	mV/A
VOQ	Zero-Current Output Voltage		-	1.65	-	V
VZCR	Zero-Current Reference Output Voltage		-	1.65	-	V
VOE_ZCR	Zero-Current Reference Output Voltage Error	$T_A = 25^\circ\text{C}$	-10	-	10	mV
		$T_A = -40^\circ\text{C}$ to 25°C	-20	-	20	mV
		$T_A = 25^\circ\text{C}$ to 150°C	-20	-	20	mV
VOE	Zero-Current Output Error VOQ-VZCR	$I_P = 0\text{ A}$, $T_A = 25^\circ\text{C}$	-5	-	5	mV
		$I_P = 0\text{ A}$, $T_A = -40^\circ\text{C}$ to 25°C	-20	-	20	mV
		$I_P = 0\text{ A}$, $T_A = 25^\circ\text{C}$ to 150°C	-15	-	15	mV
ESNST	Sensitivity Error	$I_P = 40\text{A}$, $T_A = 25^\circ\text{C}$	-	± 1.0	-	%
		$I_P = 40\text{A}$, $T_A = -40^\circ\text{C}$ to 25°C	-	± 2.5	-	%
		$I_P = 40\text{A}$, $T_A = 25^\circ\text{C}$ to 150°C	-	± 2.5	-	%
ETOT	Total Output Error	$I_P = 40\text{A}$, $T_A = 25^\circ\text{C}$	-	± 1.5	-	%
		$I_P = 40\text{A}$, $T_A = -40^\circ\text{C}$ to 25°C	-	± 3.3	-	%
		$I_P = 40\text{A}$, $T_A = 25^\circ\text{C}$ to 150°C	-	± 3.1	-	%

* Device may be operated at higher primary current levels, ambient temperatures, and internal leadframe temperatures, provided the Maximum Junction Temperature, is not exceeded.

MT9523CT-50BR3 $T_A = -40 \sim 150\text{ }^\circ\text{C}$, $V_{CC} = 3.3\text{V}$, Ratiometric mode (unless otherwise specified)

Symbol	Parameters	Test Condition	Min	Typ	Max	Unit
IPR	Input Current Range		-50	-	50	A
SNST	Sensitivity	$-50\text{A} \leq I_P \leq 50\text{A}$	-	26.4	-	mV/A
VOQ	Zero-Current Output Voltage		-	$V_{CC} \times 0.5$	-	V
VZCR	Zero-Current Reference Output Voltage		-	$V_{CC} \times 0.5$	-	V
VOE_ZCR	Zero-Current Reference Output Voltage Error	$T_A = 25^\circ\text{C}$	-10	-	10	mV
		$T_A = -40^\circ\text{C}$ to 25°C	-20	-	20	mV
		$T_A = 25^\circ\text{C}$ to 150°C	-20	-	20	mV
VOE	Zero-Current Output Error VOQ-VZCR	$I_P = 0\text{ A}$, $T_A = 25^\circ\text{C}$	-5	-	5	mV
		$I_P = 0\text{ A}$, $T_A = -40^\circ\text{C}$ to 25°C	-20	-	20	mV
		$I_P = 0\text{ A}$, $T_A = 25^\circ\text{C}$ to 150°C	-15	-	15	mV
ESNST	Sensitivity Error	$I_P = 50\text{A}$, $T_A = 25^\circ\text{C}$	-	± 1.0	-	%
		$I_P = 50\text{A}$, $T_A = -40^\circ\text{C}$ to 25°C	-	± 2.5	-	%
		$I_P = 50\text{A}$, $T_A = 25^\circ\text{C}$ to 150°C	-	± 2.5	-	%
ETOT	Total Output Error	$I_P = 50\text{A}$, $T_A = 25^\circ\text{C}$	-	± 1.5	-	%
		$I_P = 50\text{A}$, $T_A = -40^\circ\text{C}$ to 25°C	-	± 3.3	-	%
		$I_P = 50\text{A}$, $T_A = 25^\circ\text{C}$ to 150°C	-	± 3.1	-	%

* Device may be operated at higher primary current levels, ambient temperatures, and internal leadframe temperatures, provided the Maximum Junction Temperature, is not exceeded.

MT9523CT-50BF3 At $T_A = -40 \sim 150\text{ }^\circ\text{C}$, $V_{CC} = 3.3\text{V}$, Fixed mode (unless otherwise specified)

Symbol	Parameters	Test Condition	Min	Typ	Max	Unit
IPR	Input Current Range		-50	-	50	A
SNST	Sensitivity	$-50\text{A} \leq I_P \leq 50\text{A}$	-	26.4	-	mV/A
VOQ	Zero-Current Output Voltage		-	1.65	-	V
VZCR	Zero-Current Reference Output Voltage		-	1.65	-	V
VOE_ZCR	Zero-Current Reference Output Voltage Error	$T_A = 25^\circ\text{C}$	-10	-	10	mV
		$T_A = -40^\circ\text{C}$ to 25°C	-20	-	20	mV
		$T_A = 25^\circ\text{C}$ to 150°C	-20	-	20	mV
VOE	Zero-Current Output Error VOQ-VZCR	$I_P = 0\text{ A}$, $T_A = 25^\circ\text{C}$	-5	-	5	mV
		$I_P = 0\text{ A}$, $T_A = -40^\circ\text{C}$ to 25°C	-20	-	20	mV
		$I_P = 0\text{ A}$, $T_A = 25^\circ\text{C}$ to 150°C	-15	-	15	mV
ESNST	Sensitivity Error	$I_P = 50\text{A}$, $T_A = 25^\circ\text{C}$	-	± 1.0	-	%
		$I_P = 50\text{A}$, $T_A = -40^\circ\text{C}$ to 25°C	-	± 2.5	-	%
		$I_P = 50\text{A}$, $T_A = 25^\circ\text{C}$ to 150°C	-	± 2.5	-	%
ETOT	Total Output Error	$I_P = 50\text{A}$, $T_A = 25^\circ\text{C}$	-	± 1.5	-	%
		$I_P = 50\text{A}$, $T_A = -40^\circ\text{C}$ to 25°C	-	± 3.3	-	%
		$I_P = 50\text{A}$, $T_A = 25^\circ\text{C}$ to 150°C	-	± 3.1	-	%

* Device may be operated at higher primary current levels, ambient temperatures, and internal leadframe temperatures, provided the Maximum Junction Temperature, is not exceeded.

MT9523CT-10UR3 $T_A = -40 \sim 150\text{ }^\circ\text{C}$, $V_{CC} = 3.3\text{V}$, Ratiometric mode (unless otherwise specified)

Symbol	Parameters	Test Condition	Min	Typ	Max	Unit
IPR	Input Current Range		0	-	10	A
SNST	Sensitivity	$0A \leq IP \leq 10A$	-	264	-	mV/A
VOQ	Zero-Current Output Voltage		-	$V_{CC} \times 0.1$	-	V
VZCR	Zero-Current Reference Output Voltage		-	$V_{CC} \times 0.1$	-	V
VOE_ZCR	Zero-Current Reference Output Voltage Error	$T_A = 25^\circ\text{C}$	-10	-	10	mV
		$T_A = -40^\circ\text{C}$ to 25°C	-20	-	20	mV
		$T_A = 25^\circ\text{C}$ to 150°C	-20	-	20	mV
VOE	Zero-Current Output Error VOQ-VZCR	$IP = 0\text{ A}$, $T_A = 25^\circ\text{C}$	-5	-	5	mV
		$IP = 0\text{ A}$, $T_A = -40^\circ\text{C}$ to 25°C	-20	-	20	mV
		$IP = 0\text{ A}$, $T_A = 25^\circ\text{C}$ to 150°C	-25	-	25	mV
ESNST	Sensitivity Error	$IP = 10\text{A}$, $T_A = 25^\circ\text{C}$	-	± 1.0	-	%
		$IP = 10\text{A}$, $T_A = -40^\circ\text{C}$ to 25°C	-	± 2.5	-	%
		$IP = 10\text{A}$, $T_A = 25^\circ\text{C}$ to 150°C	-	± 2.2	-	%
ETOT	Total Output Error	$IP = 10\text{A}$, $T_A = 25^\circ\text{C}$	-	± 1.5	-	%
		$IP = 10\text{A}$, $T_A = -40^\circ\text{C}$ to 25°C	-	± 3.3	-	%
		$IP = 10\text{A}$, $T_A = 25^\circ\text{C}$ to 150°C	-	± 3.2	-	%

* Device may be operated at higher primary current levels, ambient temperatures, and internal leadframe temperatures, provided the Maximum Junction Temperature, is not exceeded.

MT9523CT-20UR3 At $T_A = -40 \sim 150\text{ }^\circ\text{C}$, $V_{CC} = 3.3\text{V}$, Ratiometric mode (unless otherwise specified)

Symbol	Parameters	Test Condition	Min	Typ	Max	Unit
IPR	Input Current Range		0	-	20	A
SNST	Sensitivity	$0A \leq IP \leq 20A$	-	132	-	mV/A
VOQ	Zero-Current Output Voltage		-	$V_{CC} \times 0.1$	-	V
VZCR	Zero-Current Reference Output Voltage		-	$V_{CC} \times 0.1$	-	V
VOE_ZCR	Zero-Current Reference Output Voltage Error	$T_A = 25^\circ\text{C}$	-10	-	10	mV
		$T_A = -40^\circ\text{C}$ to 25°C	-20	-	20	mV
		$T_A = 25^\circ\text{C}$ to 150°C	-20	-	20	mV
VOE	Zero-Current Output Error VOQ-VZCR	$IP = 0\text{ A}$, $T_A = 25^\circ\text{C}$	-5	-	5	mV
		$IP = 0\text{ A}$, $T_A = -40^\circ\text{C}$ to 25°C	-20	-	20	mV
		$IP = 0\text{ A}$, $T_A = 25^\circ\text{C}$ to 150°C	-15	-	15	mV
ESNST	Sensitivity Error	$IP = 20\text{A}$, $T_A = 25^\circ\text{C}$	-	± 1.0	-	%
		$IP = 20\text{A}$, $T_A = -40^\circ\text{C}$ to 25°C	-	± 2.5	-	%
		$IP = 20\text{A}$, $T_A = 25^\circ\text{C}$ to 150°C	-	± 2.2	-	%
ETOT	Total Output Error	$IP = 20\text{A}$, $T_A = 25^\circ\text{C}$	-	± 1.5	-	%
		$IP = 20\text{A}$, $T_A = -40^\circ\text{C}$ to 25°C	-	± 3.3	-	%
		$IP = 20\text{A}$, $T_A = 25^\circ\text{C}$ to 150°C	-	± 2.8	-	%

* Device may be operated at higher primary current levels, ambient temperatures, and internal leadframe temperatures, provided the Maximum Junction Temperature, is not exceeded.

MT9523CT-30UR3 $T_A = -40 \sim 150\text{ }^\circ\text{C}$, $V_{CC} = 3.3\text{V}$, Ratiometric mode (unless otherwise specified)

Symbol	Parameters	Test Condition	Min	Typ	Max	Unit
IPR	Input Current Range		0	-	30	A
SNST	Sensitivity	$0A \leq IP \leq 30A$	-	132	-	mV/A
VOQ	Zero-Current Output Voltage		-	$V_{CC} \times 0.1$	-	V
VZCR	Zero-Current Reference Output Voltage		-	$V_{CC} \times 0.1$	-	V
VOE_ZCR	Zero-Current Reference Output Voltage Error	$T_A = 25^\circ\text{C}$	-10	-	10	mV
		$T_A = -40^\circ\text{C}$ to 25°C	-20	-	20	mV
		$T_A = 25^\circ\text{C}$ to 150°C	-20	-	20	mV
VOE	Zero-Current Output Error VOQ-VZCR	$IP = 0\text{ A}$, $T_A = 25^\circ\text{C}$	-5	-	5	mV
		$IP = 0\text{ A}$, $T_A = -40^\circ\text{C}$ to 25°C	-20	-	20	mV
		$IP = 0\text{ A}$, $T_A = 25^\circ\text{C}$ to 150°C	-15	-	15	mV
ESNST	Sensitivity Error	$IP = 30\text{A}$, $T_A = 25^\circ\text{C}$	-	± 1.0	-	%
		$IP = 30\text{A}$, $T_A = -40^\circ\text{C}$ to 25°C	-	± 2.5	-	%
		$IP = 30\text{A}$, $T_A = 25^\circ\text{C}$ to 150°C	-	± 2.2	-	%
ETOT	Total Output Error	$IP = 30\text{A}$, $T_A = 25^\circ\text{C}$	-	± 1.5	-	%
		$IP = 30\text{A}$, $T_A = -40^\circ\text{C}$ to 25°C	-	± 3.3	-	%
		$IP = 30\text{A}$, $T_A = 25^\circ\text{C}$ to 150°C	-	± 2.8	-	%

* Device may be operated at higher primary current levels, ambient temperatures, and internal leadframe temperatures, provided the Maximum Junction Temperature, is not exceeded.

11 Characteristic Definitions

Power On Time---TPO

When the supply is ramped to its operating voltage, the device requires a finite time to power its internal components before responding to an input magnetic field.

The Power-On Time (TPO) is defined as the time taken between the supply reaching the minimum operating voltage V_{CCmin} (t_1), and the output voltage to settling to within $\pm 10\%$ of its steady state value under an applied magnetic field (t_2) (See Figure 5).

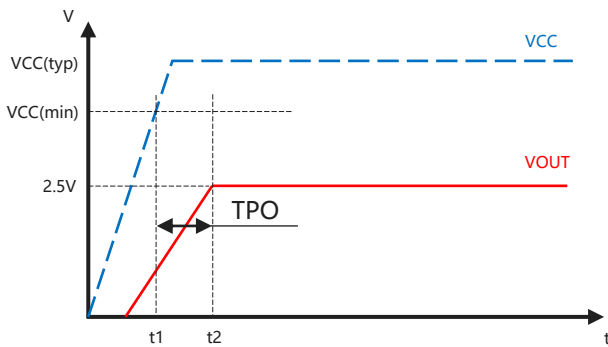

Figure.5 Power On Time Definition

Propagation Delay---TPD

The time interval between a) when the primary current signal reaches 20% of its final value, and b) when the output reaches 20% of its final value (see Figure 6).

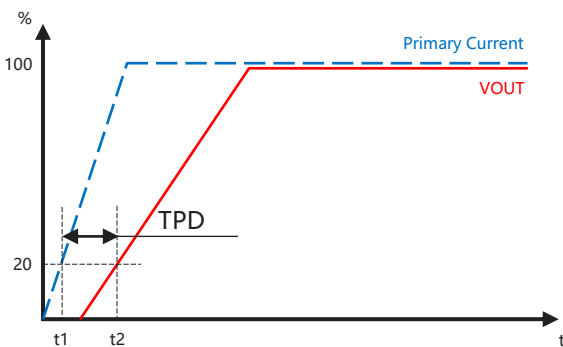

Figure.6 Propagation Delay Definition

Rise Time---TR

Rise Time is the time interval between the sensor VOUT reaching 10% of its full scale value (t_1), and it reaching 90% of its full scale value (t_2). (see Figure 7). Both TR and TRESP can be negatively affected by any eddy current losses created if a conductive ground plane is used.

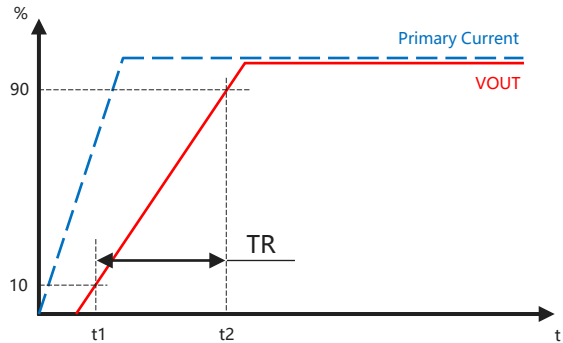

Figure.7 Rise Time Definition

Response Time---TRES

The time interval between a) when the primary current signal reaches 80% of its final value, and b) when the sensor reaches 80% of its output corresponding to the applied current. (see Figure 8). Both TR and TRES can be negatively affected by any eddy current losses created if a conductive ground plane is used.

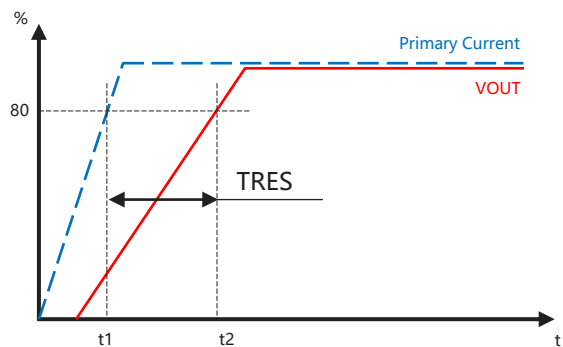

Figure.8 Response Time Definition

Zero-Current Output Voltage---VOQ

VOQ is the voltage output when the primary current is zero. For Ratiometric mode, the bidirectional device is $0.5 \times VCC$ and the unidirectional device is $0.1 \times VCC$ when the primary current is zero. For Fixed mode, the bidirectional device is 2.5V or 1.65V and the unidirectional device is 0.5V or 0.33V, when the primary current is zero.

Ratiometric Mode:

When $VCC=4.5V$, $VOQ=1/2 \times VCC$, $VOQ=2.25V$

Fixed Mode:

When $VCC=4.5 \sim 5.5V$, $VOQ=2.5V$

Zero-Current Reference Voltage---VZCR

MT9522 provides two different zero current reference voltage output (VZCR), one is the voltage reference output independent of the supply voltage (BF / UF), and the other is the voltage reference output proportional to the supply voltage (BR / UR). Users can know the output voltage corresponding to zero current through VOUT and VZCR. At the same time, it allows users to use either single ended output measurement or differential measurement

Ratiometric Mode:

When $VCC=5.5V$, $VZCR=1/2 \times VCC$, $VZCR=2.75V$

Fixed Mode:

When $VCC=4.5 \sim 5.5V$, $VZCR=2.5V$

Sensitivity---SNST

The Sensitivity in mV/A indicates how much the output changes when the primary current changes. It is the product of the magnetic circuit sensitivity (G/A) ($1G = 0.1mT$) and the linear IC amplifier gain (mV/G). The linear IC amplifier gain is programmed at the factory to optimize the sensitivity (mV/A) for the full-scale current of the device.

$$SNST = \left(\frac{VOUT_IPOSx - VOUT_INEGx}{IPOSx - INEGx} \right)$$

where IPOSx and INEGx are two current values with opposite polarities.

Zero-Current Output Error---VOE (VOQ-VZCR)

The deviation of the device output from its ideal quiescent due to nonmagnetic causes. To convert this voltage to amp, divide by the device sensitivity (SNST).

Total Output Error---ETOT

The accuracy represents the maximum deviation of the actual current output from its ideal current value. This is equivalent to the difference between the actual output voltage and the ideal output voltage, divided by the ideal sensitivity, relative to the current flowing through the primary conduction path:

$$ETOT(IP) = \left(\frac{VOUT_IP - VOUT_ideal(IP)}{SNST_ideal \cdot IP} \right) * 100\%$$

Nonlinearity Sensitivity Error---ELIN

Ideally the primary current vs sensor output function is a straight line. The non-linearity is an indication of the worst deviation from this straight line. The ELIN in % is defined as:

$$ELIN = \left(\frac{SNST_I1}{SNST_I2} - 1 \right) * 100\%$$

Where:

$$SNST_I1 = \left(\frac{VOUT_IPOS1 - VOUT_INEG1}{IPOS1 - INEG1} \right)$$

$$SNST_I2 = \left(\frac{VOUT_IPOS2 - VOUT_INEG2}{IPOS2 - INEG2} \right)$$

and IPOSx and INEGx are positive and negative current values, with respect to the quiescent voltage output such that $|IPOS2| = |INEG2| = IPRmax$, and $|IPOS1| = 2 \times |IPOS2|$ and $|INEG1| = 2 \times |INEG2|$.

Power Supply Rejection Ratio VOQ---PSRR VOQ

It is defined as 20 × log of the ratio of the % change the VOQ over the % change in VCC reported as dB in a specified frequency range.

$$PSRR_VOQ=20 \lg \left| \frac{\Delta VOQ}{\Delta VCC} \right|$$

For Example:

When VCC changes from 5V to 4.5V (i.e. change - 500mv), VOQ changes from 2.5V to 2.505V (i.e. change 5mV), then

$$PSRR_VZCR=20 \lg \left| \frac{5}{-500} \right| = -40dB$$

Power Supply Rejection Ratio VZCR---PSRR VZCR

It is defined as 20 × log of the ratio of the % change the VZCR over the % change in VCC reported as dB in a specified frequency range.

$$PSRR_VOQ=20 \lg \left| \frac{\Delta VZCR}{\Delta VCC} \right|$$

For Example:

When VCC changes from 5V to 5.5V (i.e. change 500mv) and vzcr changes from 2.5V to 2.497V (i.e. change - 3mV), then

$$PSRR_VZCR=20 \lg \left| \frac{-3}{500} \right| = -44.437dB$$

Power Supply Rejection Ratio SNST---PSRR SNST

It is defined as 20 × log of the ratio of the % change the SNST over the % change in VCC reported as dB in a specified frequency range.

$$PSRR_SNST=20 \lg \left| \frac{\Delta SNST\%}{\Delta VCC\%} \right|$$

For Example:

When VCC changes from 5V to 4.5V (i.e. change - 10%), the sensitivity changes from 100mV / A to 99.9mv/a (i.e. change -0.1%), then

$$PSRR_SNST=20 \lg \left| \frac{-0.1\%}{-10\%} \right| = -40dB$$

Ratiometry Error---ERAT

For ratiometric mode, this means that the zero-current voltage output (VOQ) and sensitivity (SNST) are proportional to the supply voltage (Vcc). In other words, when the supply voltage increases or decreases by a certain percentage, each characteristic also increases or decreases by the same percentage. The error is the difference between the measured change of power supply voltage relative to 5V or 3.3V and the measured change of each characteristic

Ratiometry Quiescent Voltage Output Error---ERAT VOQ

ERAT_VOQ, for a given supply voltage, is defined as:

$$ERAT_VOQ(5V)=\left(\frac{VOQ(VCC)/VCC}{VOQ(5V)/5V}-1\right)*100\%$$

$$ERAT_VOQ(3.3V)=\left(\frac{VOQ(VCC)/VCC}{VOQ(3.3V)/3.3V}-1\right)*100\%$$

Ratiometry Sensitivity Error---ERAT SNST

ERAT_SNST, for a given supply voltage, is defined as:

$$ERAT_SNST(5V)=\left(\frac{SNST_I1(VCC)/VCC}{SNST_I1(5V)/5V}-1\right)*100\%$$

$$ERAT_SNST(3.3V)=\left(\frac{SNST_I1(VCC)/VCC}{SNST_I1(3.3V)/3.3V}-1\right)*100\%$$

Power-On Reset---POR, Undervoltage Lockout---UVL

The descriptions in this section assume temperature = 25°C, no output load (RL, CL) , and no significant magnetic field is present.

Power-Up. At power-up, as VCC ramps up, the output is in the following power supply voltage state. When VCC exceeds VPORH, the chip will enter the handshake protocol state. When VCC exceeds VUVLH, the output will go to 1/2*VCC or 2.5V, at this time, the chip is in normal working state.

Power-Down. If VCC drops below VUVLL, the output will be in a high-impedance state. If VCC drops below VPORL, the output is in the following power supply voltage state (See Figure. 9).

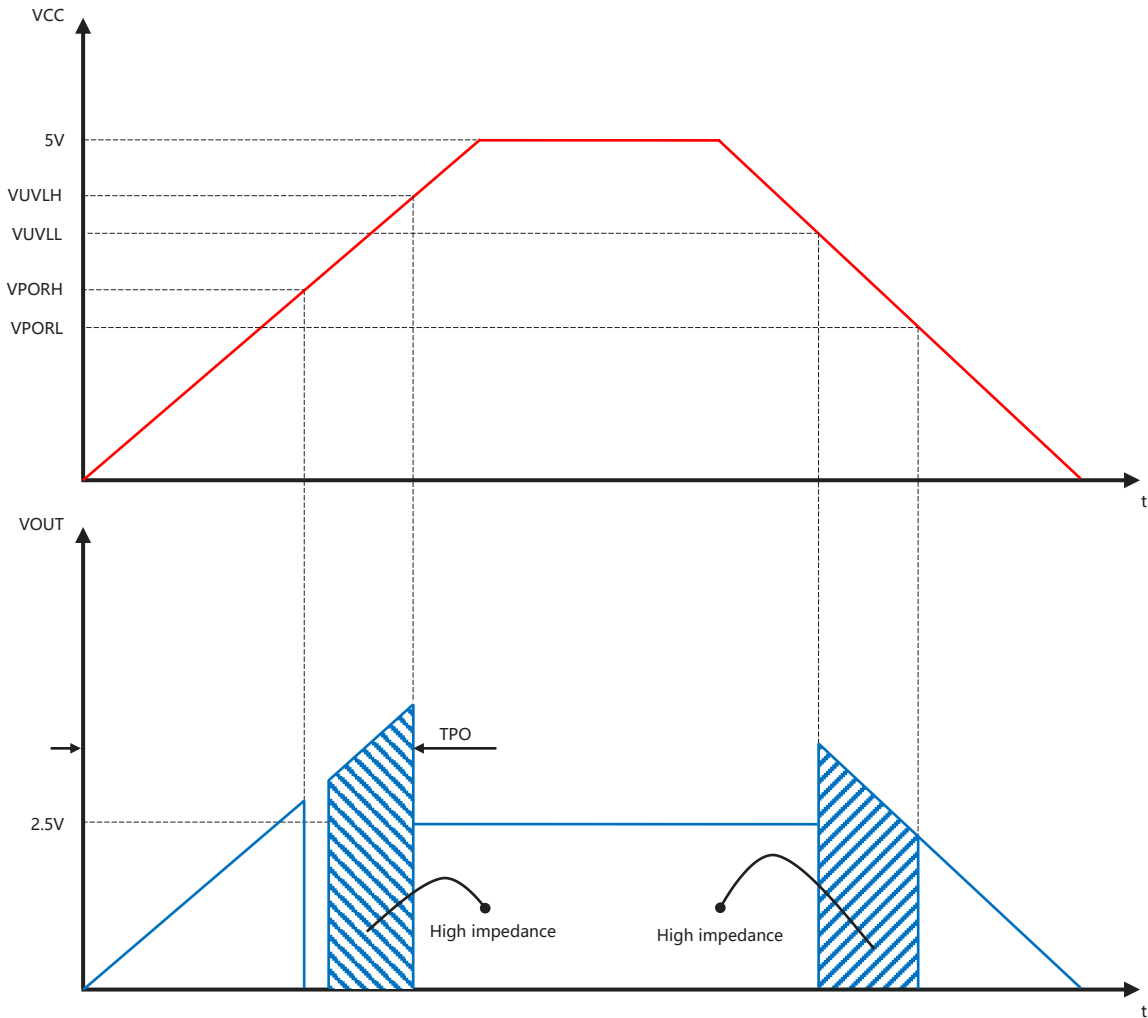
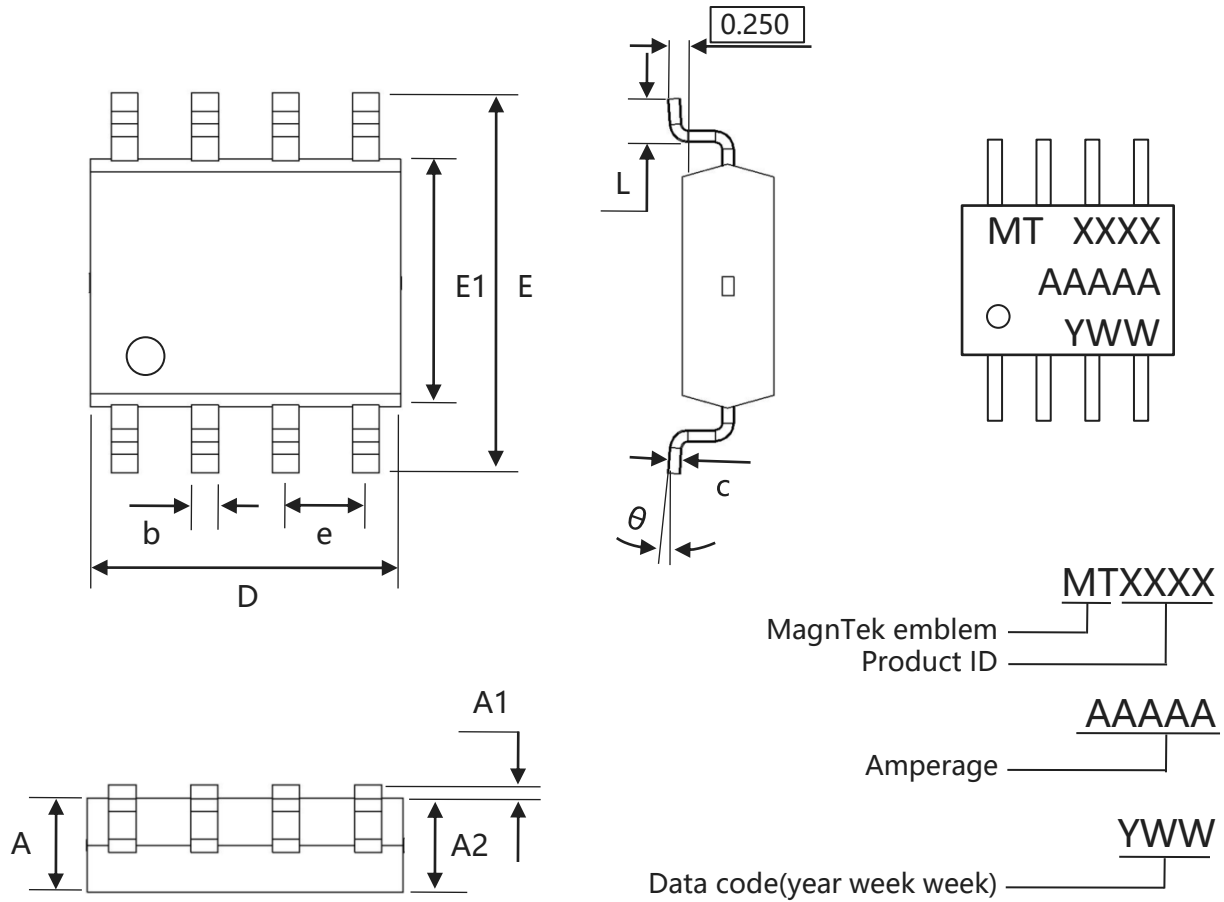

Figure.9 POR and UVL Definition

12 Package Material Information (For Reference Only – Not for Tooling Use)

12.1 SOP-8 Package Information



Symbol	Dimensions in Millimeters		Dimensions in Inches	
	Min	Max	Min	Max
A	1.450	1.750	0.057	0.069
A1	0.100	0.250	0.004	0.010
A2	1.350	1.550	0.053	0.061
b	0.330	0.510	0.013	0.020
c	0.170	0.250	0.007	0.010
D	4.700	5.100	0.185	0.201
E	5.800	6.200	0.228	0.244
E1	3.800	4.000	0.150	0.157
e	1.270(BSC)		0.050(BSC)	
L	0.400	1.270	0.016	0.050
θ	0°	8°	0°	8°

13 Copy Rights and Disclaimer

1. This document may not be reproduced or duplicated, in any form, in whole or in part without prior written consent of MagnTek . Copyrights © 2019, MagnTek Incorporated.
2. MagnTek reserves the right to make changes to the information published in this document at anytime without notice.
3. MagnTek' s products are limited for use in normal commercial applications. MagnTek' s products are not to be used in any device or system, including but not limited to medical life support equipment and system.

For the latest version of this document, please visit our website: www.magntek.com.cn